

I²S bus specification

1.0 INTRODUCTION

Many digital audio systems are being introduced into the consumer audio market, including compact disc, digital audio tape, digital sound processors, and digital TV-sound. The digital audio signals in these systems are being processed by a number of (V)LSI ICs, such as:

- A/D and D/A converters;
- digital signal processors;
- error correction for compact disc and digital recording;
- digital filters;
- digital input/output interfaces.

Standardized communication structures are vital for both the equipment and the IC manufacturer, because they increase system flexibility. To this end, we have developed the inter-IC sound (I²S) bus – a serial link especially for digital audio.

2.0 BASIC SERIAL BUS REQUIREMENTS

The bus has only to handle audio data, while the other signals, such as sub-coding and control, are transferred separately. To minimize the number of pins required and to keep wiring simple, a 3-line serial bus is used consisting of a line for two time-multiplexed data channels, a word select line and a clock line.

Since the transmitter and receiver have the same clock signal for data transmission, the transmitter as the master, has to generate the bit clock, word-select signal and data. In complex systems however, there may be several transmitters and receivers, which makes it difficult to define the master. In such systems, there is usually a system master controlling digital audio data-flow between the various ICs. Transmitters then, have to generate data under the control of an external clock, and so act as a slave. Figure 1 illustrates some simple system configurations and the basic interface timing. Note that the system master can be combined with a transmitter or receiver, and it may be enabled or disabled under software control or by pin programming.

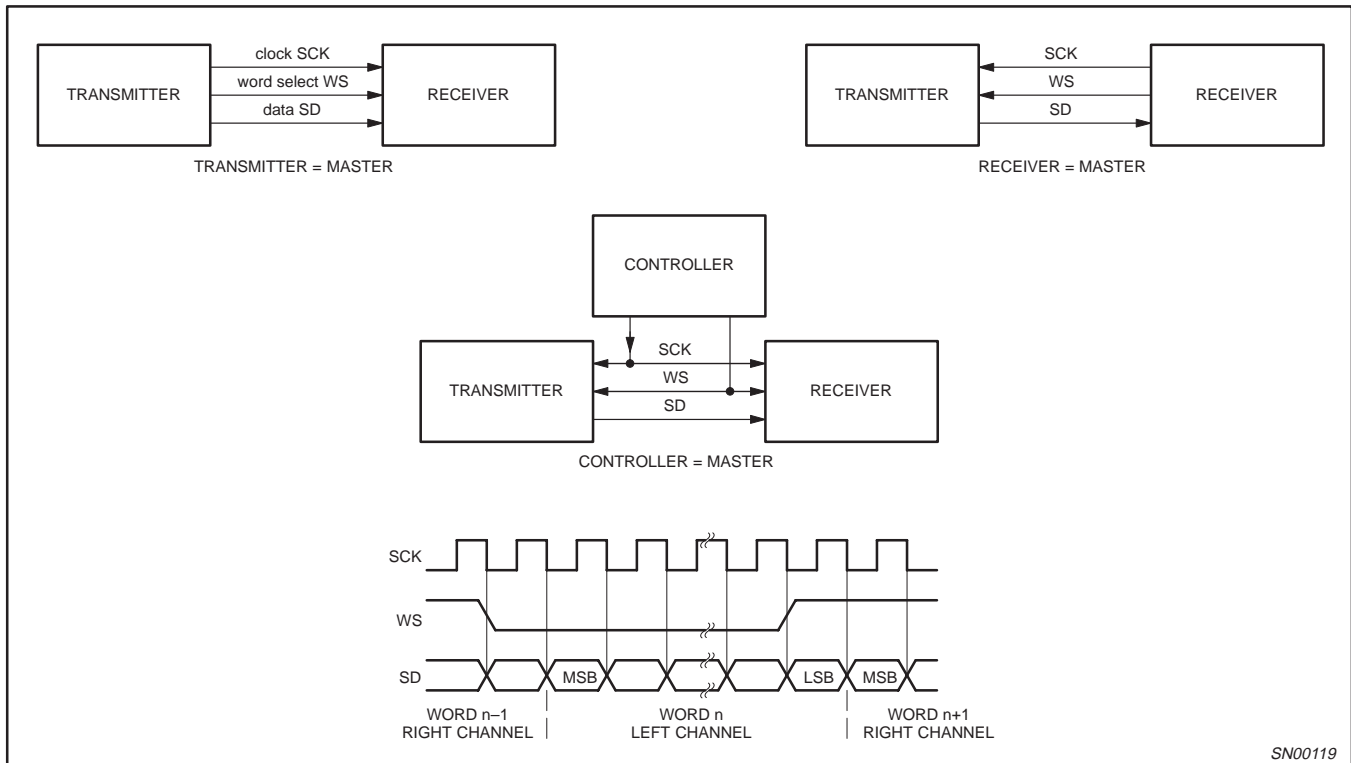

Figure 1. Simple System Configurations and Basic Interface Timing

SN00119

I²S bus specification

3.0 THE I²S BUS

As shown in Figure 1, the bus has three lines:

- continuous serial clock (SCK);
- word select (WS);
- serial data (SD);

and the device generating SCK and WS is the master.

3.1 Serial Data

Serial data is transmitted in two's complement with the MSB first. The MSB is transmitted first because the transmitter and receiver may have different word lengths. It isn't necessary for the transmitter to know how many bits the receiver can handle, nor does the receiver need to know how many bits are being transmitted.

When the system word length is greater than the transmitter word length, the word is truncated (least significant data bits are set to '0') for data transmission. If the receiver is sent more bits than its word length, the bits after the LSB are ignored. On the other hand, if the receiver is sent fewer bits than its word length, the missing bits are set to zero internally. And so, the MSB has a fixed position, whereas the position of the LSB depends on the word length. The transmitter always sends the MSB of the next word one clock period after the WS changes.

Serial data sent by the transmitter may be synchronized with either the trailing (HIGH-to-LOW) or the leading (LOW-to-HIGH) edge of the clock signal. However, the serial data must be latched into the receiver on the leading edge of the serial clock signal, and so there are some restrictions when transmitting data that is synchronized with the leading edge (see Figure 2 and Table 1).

3.2 Word Select

The word select line indicates the channel being transmitted:

- WS = 0; channel 1 (left);
- WS = 1; channel 2 (right).

WS may change either on a trailing or leading edge of the serial clock, but it doesn't need to be symmetrical. In the slave, this signal

is latched on the leading edge of the clock signal. The WS line changes one clock period before the MSB is transmitted. This allows the slave transmitter to derive synchronous timing of the serial data that will be set up for transmission. Furthermore, it enables the receiver to store the previous word and clear the input for the next word (see Figure 1).

4.0 TIMING

In the I²S format, any device can act as the system master by providing the necessary clock signals. A slave will usually derive its internal clock signal from an external clock input. This means, taking into account the propagation delays between master clock and the data and/or word-select signals, that the total delay is simply the sum of:

- the delay between the external (master) clock and the slave's internal clock; and
- the delay between the internal clock and the data and/or word-select signals.

For data and word-select inputs, the external to internal clock delay is of no consequence because it only lengthens the effective set-up time (see Figure 2). The major part of the time margin is to accommodate the difference between the propagation delay of the transmitter, and the time required to set up the receiver.

All timing requirements are specified relative to the clock period or to the minimum allowed clock period of a device. This means that higher data rates can be used in the future.

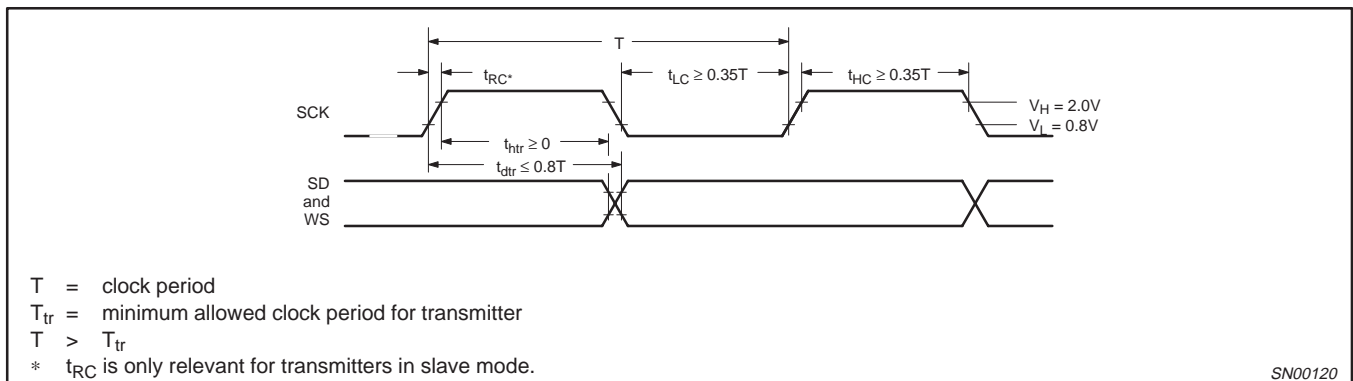

Figure 2. Timing for I²S Transmitter

I²S bus specification

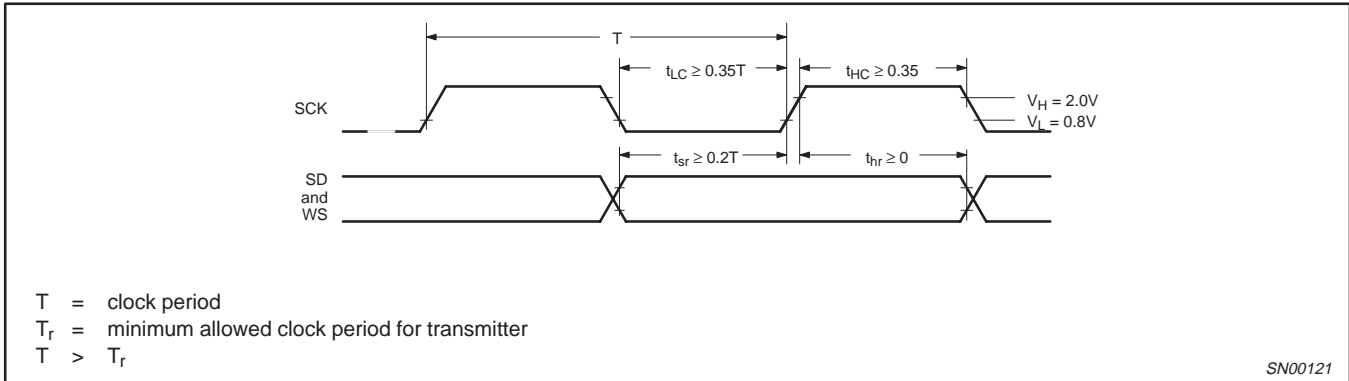

Figure 3. Timing for I²S Receiver

Note that the times given in both Figures 2 and 3 are defined by the transmitter speed. The specification of the receiver has to be able to match the performance of the transmitter

Example: Master transmitter with data rate of 2.5MHz (±10%) (all values in ns)

	MIN	TYP	MAX	CONDITION
clock period T	360	400	440	$T_{tr} = 360$
clock HIGH t_{HC}	160			min $> 0.35T = 140$ (at typical data rate)
clock LOW t_{LC}	160			min $> 0.35T = 140$ (at typical data rate)
delay t_{dtr}			300	max $< 0.80T = 320$ (at typical data rate)
hold time t_{hr}	100			min > 0
clock rise-time t_{RC}			60	max $> 0.15T_{tr} = 54$ (only relevant in slave mode)

Example: Slave receiver with data rate of 2.5MHz (±10%) (all values in ns)

	MIN	TYP	MAX	CONDITION
clock period T	360	400	440	$T_{tr} = 360$
clock HIGH t_{HC}	110			min $< 0.35T = 126$
clock LOW t_{LC}	110			min $< 0.35T = 126$
set-up time t_{sr}	60			min $< 0.20T = 72$
hold time t_{hr}	0			min < 0

I²S bus specification

Table 1. Timing for I²S transmitters and receivers

	TRANSMITTER				RECEIVER				NOTES
	LOWER LIMIT		UPPER LIMIT		LOWER LIMIT		UPPER LIMIT		
	MIN	MAX	MIN	MAX	MIN	MAX	MIN	MAX	
Clock period T	T_{tr}				T_r				1
MASTER MODE: clock generated by transmitter or receiver: HIGH t_{HC} LOW t_{LC}	$0.35T_{tr}$ $0.35T_{tr}$				$0.35T_{tr}$ $0.35T_{tr}$				2a 2a
SLAVE MODE: clock accepted by transmitter or receiver: HIGH t_{HC} LOW t_{LC} rise-time t_{RC}		$0.35T_{tr}$ $0.35T_{tr}$		$0.15T_{tr}$		$0.35T_r$ $0.35T_r$			2b 2b 3
TRANSMITTER: delay t_{dtr} hold time t_{htr}				$0.8T$					4 3
RECEIVER: set-up time t_{sr} hold time t_{hr}						$0.2T_r$ 0			5 5

All timing values are specified with respect to high and low threshold levels.

NOTES:

1. The system clock period T must be greater than T_{tr} and T_r because both the transmitter and receiver have to be able to handle the data transfer rate.
- 2a. At all data rates in the master mode, the transmitter or receiver generates a clock signal with a fixed mark/space ratio. For this reason t_{HC} and t_{LC} are specified with respect to T.
- 2b. In the slave mode, the transmitter and receiver need a clock signal with minimum HIGH and LOW periods so that they can detect the signal. So long as the minimum periods are greater than $0.35T_r$, any clock that meets the requirements can be used (see Figure 3).
3. Because the delay (t_{dtr}) and the maximum transmitter speed (defined by T_{tr}) are related, a fast transmitter driven by a slow clock edge can result in t_{dtr} not exceeding t_{RC} which means t_{htr} becomes zero or negative. Therefore, the transmitter has to guarantee that t_{htr} is greater than or equal to zero, so long as the clock rise-time t_{RC} is not more than t_{RCmax} , where t_{RCmax} is not less than $0.15T_{tr}$.
4. To allow data to be clocked out on a falling edge, the delay is specified with respect to the rising edge of the clock signal and T, always giving the receiver sufficient set-up time.
5. The data set-up and hold time must not be less than the specified receiver set-up and hold time.

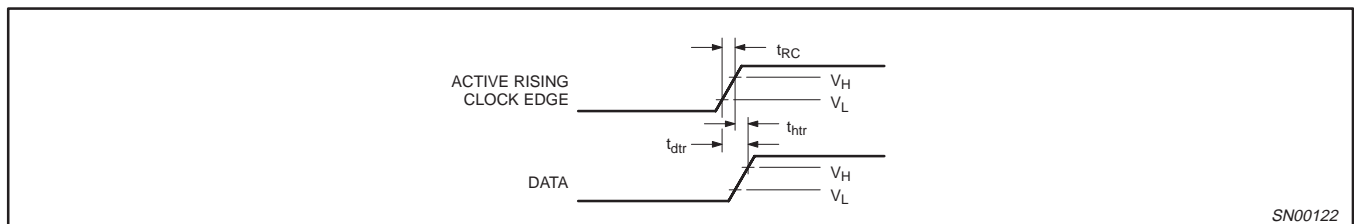

Figure 4. Clock rise-time definition with respect to the voltage levels

I²S bus specification

5.0 VOLTAGE LEVEL SPECIFICATION

5.1 Output Levels

$V_L < 0.4V$
 $V_H > 2.4V$ both levels able to drive one standard TTL input ($I_{IL} = -1.6mA$ and $I_{IH} = 0.04mA$).

5.2 Input Levels

$V_{IL} = 0.8V$
 $V_{IH} = 2.0V$

Note: At present, TTL is considered a standard for logic levels. As other IC (LSI) technologies become popular, other levels will also be supported.

6.0 POSSIBLE HARDWARE CONFIGURATIONS

6.1 Transmitter (see Figure 5)

At each WS-level change, a pulse WSP is derived for synchronously parallel-loading the shift register. The output of one of the data latches is then enabled depending on the WS signal. Since the serial data input is zero, all the bits after the LSB will also be zero.

6.2 Receiver (see Figure 6)

Following the first WS-level change, WSP will reset the counter on the falling edge of SCK. After decoding the counter value in a "1 out of n" decoder, the MSB latch (B1) is enabled ($EN1 = 1$), and the first serial data bit (the MSB) is latched into B1 on the rising edge of SCK. As the counter increases by one every clock pulse, subsequent data bits are latched into B2 to Bn.

On the next WS-level change, the contents of the n latches are written in parallel, depending on WSD, into either the left or the right data-word latch. After this, latches B2 to Bn are cleared and the counter reset. If there are more than n serial data bits to be latched, the counter is inhibited after Bn (the receiver's LSB) is filled and subsequent bits are ignored.

Note: The counter and decoder can be replaced by an n-bit shift-register (see Figure 7) in which a single '1' is loaded into the MSB position when WSP occurs. On every subsequent clock pulse, this '1' shifts one place, enabling the N latches. This configuration may prove useful if the layout has to be taken into account.

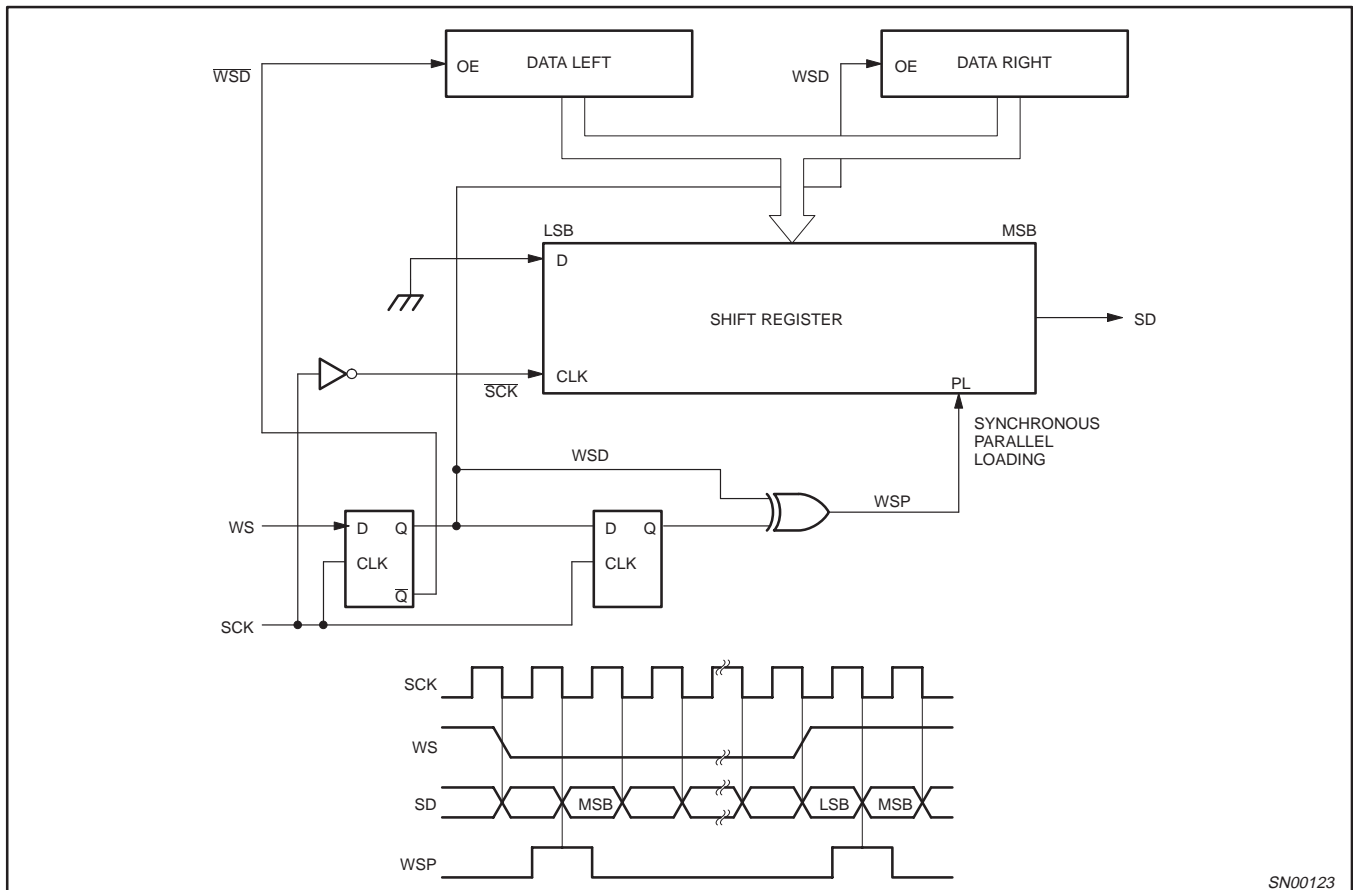

Figure 5. Possible transmitter configuration

SN00123

I²S bus specification

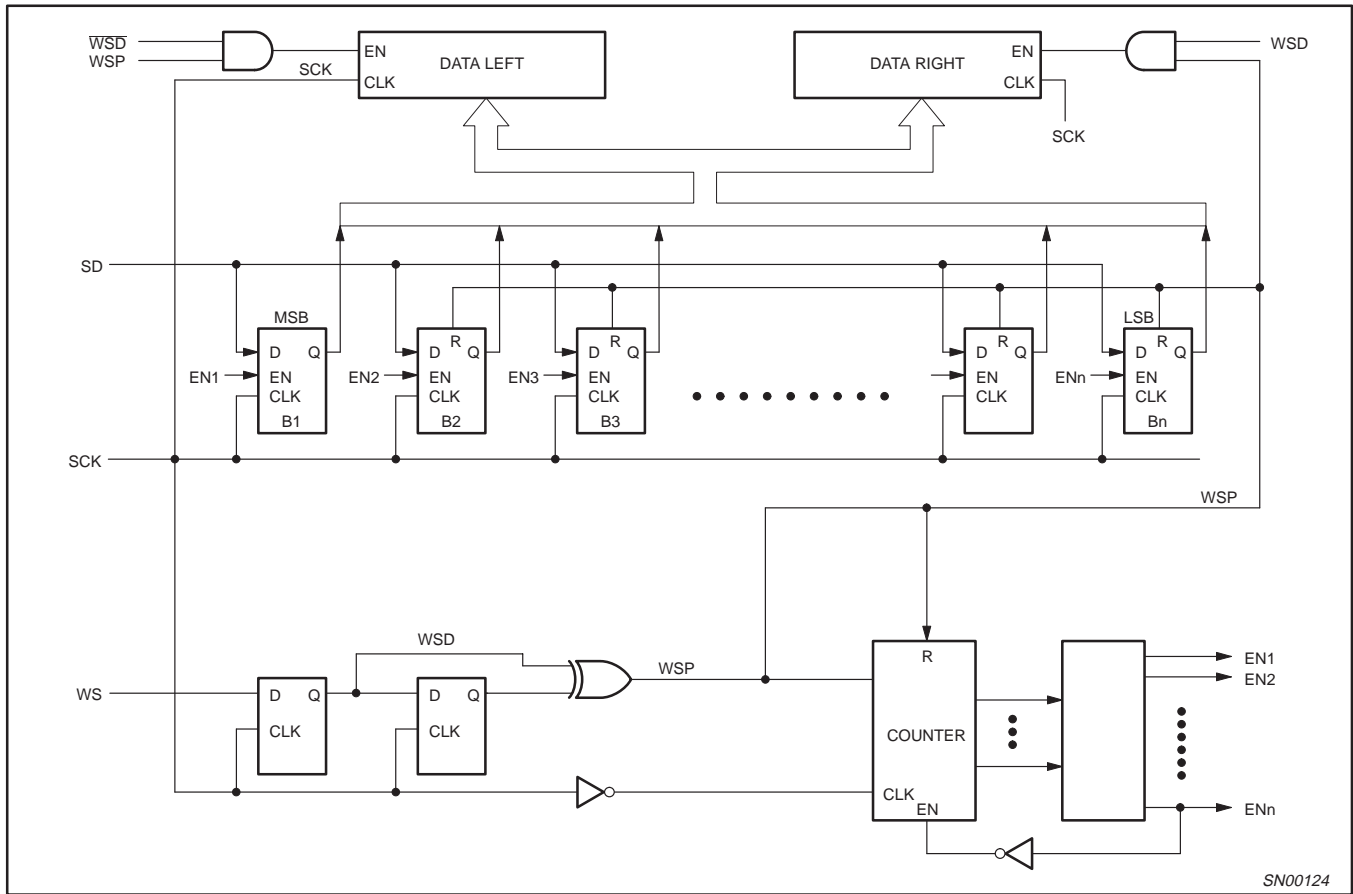

Figure 6. Possible receiver configuration. The latches and the counter use synchronous set, reset and enable inputs, where set overrules the reset input, and reset overrules the enable input.

I²S bus specification

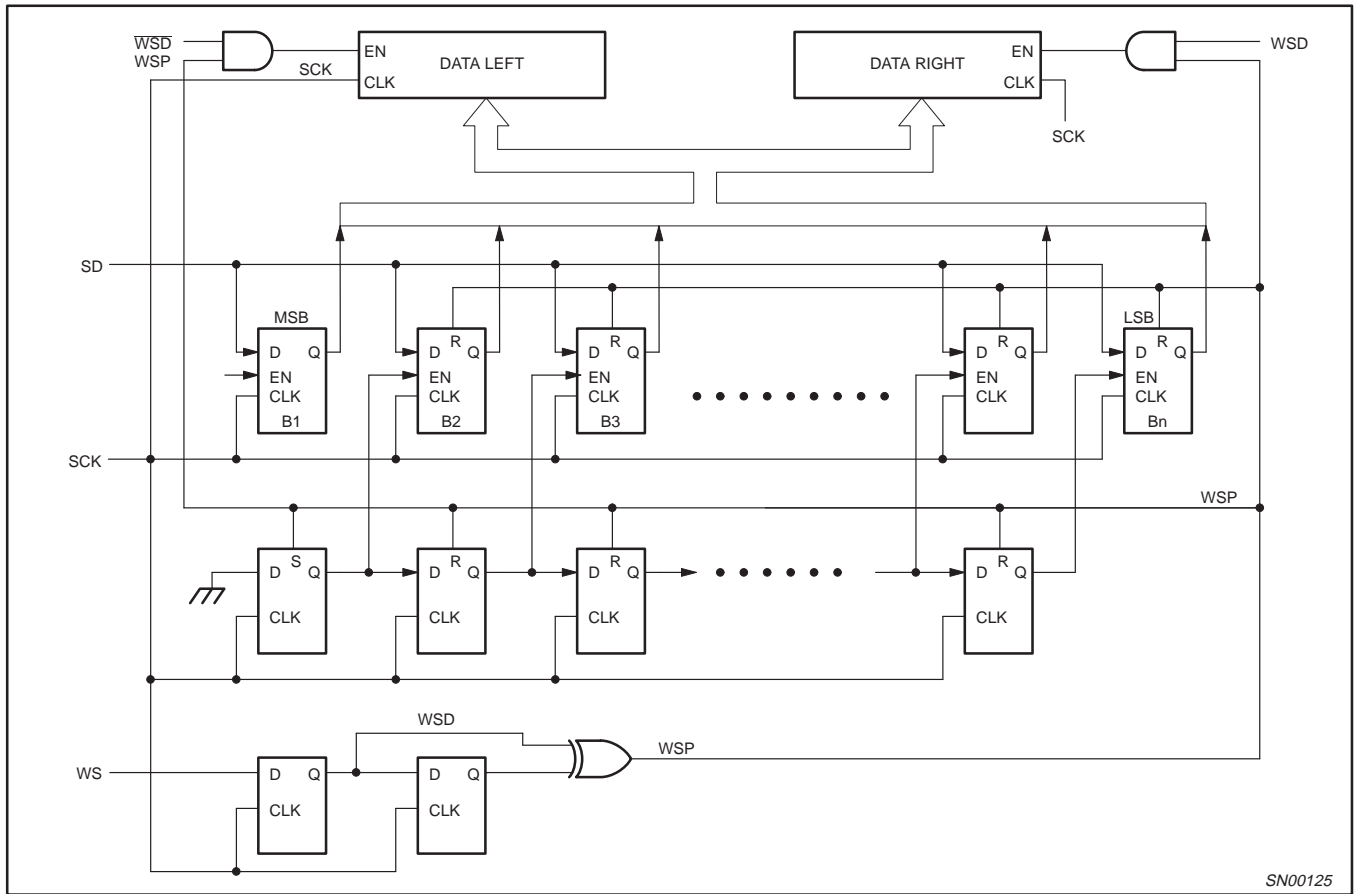

Figure 7. Possible receiver configuration, using an n-bit shift-register to enable control of data input register.

SN00125

射频和天线设计培训课程推荐

易迪拓培训(www.edatop.com)由数名来自于研发第一线的资深工程师发起成立,致力并专注于微波、射频、天线设计研发人才的培养;我们于 2006 年整合合并微波 EDA 网(www.mweda.com),现已发展成为国内最大的微波射频和天线设计人才培养基地,成功推出多套微波射频以及天线设计经典培训课程和 ADS、HFSS 等专业软件使用培训课程,广受客户好评;并先后与人民邮电出版社、电子工业出版社合作出版了多本专业图书,帮助数万名工程师提升了专业技术能力。客户遍布中兴通讯、研通高频、埃威航电、国人通信等多家国内知名公司,以及台湾工业技术研究院、永业科技、全一电子等多家台湾地区企业。

易迪拓培训课程列表: <http://www.edatop.com/peixun/rfe/129.html>



射频工程师养成培训课程套装

该套装精选了射频专业基础培训课程、射频仿真设计培训课程和射频电路测量培训课程三个类别共 30 门视频培训课程和 3 本图书教材;旨在引领学员全面学习一个射频工程师需要熟悉、理解和掌握的专业知识和研发设计能力。通过套装的学习,能够让学员完全达到和胜任一个合格的射频工程师的要求...

课程网址: <http://www.edatop.com/peixun/rfe/110.html>

ADS 学习培训课程套装

该套装是迄今国内最全面、最权威的 ADS 培训教程,共包含 10 门 ADS 学习培训课程。课程是由具有多年 ADS 使用经验的微波射频与通信系统设计领域资深专家讲解,并多结合设计实例,由浅入深、详细而又全面地讲解了 ADS 在微波射频电路设计、通信系统设计和电磁仿真设计方面的内容。能让您在最短的时间内学会使用 ADS,迅速提升个人技术能力,把 ADS 真正应用到实际研发工作中去,成为 ADS 设计专家...



课程网址: <http://www.edatop.com/peixun/ads/13.html>



HFSS 学习培训课程套装

该套课程套装包含了本站全部 HFSS 培训课程,是迄今国内最全面、最专业的 HFSS 培训教程套装,可以帮助您从零开始,全面深入学习 HFSS 的各项功能和在多个方面的工程应用。购买套装,更可超值赠送 3 个月免费学习答疑,随时解答您学习过程中遇到的棘手问题,让您的 HFSS 学习更加轻松顺畅...

课程网址: <http://www.edatop.com/peixun/hfss/11.html>

CST 学习培训课程套装

该培训套装由易迪拓培训联合微波 EDA 网共同推出,是最全面、系统、专业的 CST 微波工作室培训课程套装,所有课程都由经验丰富的专家授课,视频教学,可以帮助您从零开始,全面系统地学习 CST 微波工作的各项功能及其在微波射频、天线设计等领域的设计应用。且购买该套装,还可超值赠送 3 个月免费学习答疑...

课程网址: <http://www.edatop.com/peixun/cst/24.html>



HFSS 天线设计培训课程套装

套装包含 6 门视频课程和 1 本图书,课程从基础讲起,内容由浅入深,理论介绍和实际操作讲解相结合,全面系统的讲解了 HFSS 天线设计的全过程。是国内最全面、最专业的 HFSS 天线设计课程,可以帮助您快速学习掌握如何使用 HFSS 设计天线,让天线设计不再难...

课程网址: <http://www.edatop.com/peixun/hfss/122.html>

13.56MHz NFC/RFID 线圈天线设计培训课程套装

套装包含 4 门视频培训课程,培训将 13.56MHz 线圈天线设计原理和仿真设计实践相结合,全面系统地讲解了 13.56MHz 线圈天线的工作原理、设计方法、设计考量以及使用 HFSS 和 CST 仿真分析线圈天线的具体操作,同时还介绍了 13.56MHz 线圈天线匹配电路的设计和调试。通过该套课程的学习,可以帮助您快速学习掌握 13.56MHz 线圈天线及其匹配电路的原理、设计和调试...

详情浏览: <http://www.edatop.com/peixun/antenna/116.html>



我们的课程优势:

- ※ 成立于 2004 年,10 多年丰富的行业经验,
- ※ 一直致力并专注于微波射频和天线设计工程师的培养,更了解该行业对人才的要求
- ※ 经验丰富的一线资深工程师讲授,结合实际工程案例,直观、实用、易学

联系我们:

- ※ 易迪拓培训官网: <http://www.edatop.com>
- ※ 微波 EDA 网: <http://www.mweda.com>
- ※ 官方淘宝店: <http://shop36920890.taobao.com>