

THE I²C-BUS SPECIFICATION

VERSION 2.1

JANUARY 2000

The I²C-bus specification

CONTENTS

1	PREFACE	3	13.4	Hs-mode devices at lower speed modes	24
1.1	Version 1.0 - 1992	3	13.5	Mixed speed modes on one serial bus system	24
1.2	Version 2.0 - 198	3	13.5.1	F/S-mode transfer in a mixed-speed bus system	25
1.3	Version 2.1 - 1999	3	13.5.2	Hs-mode transfer in a mixed-speed bus system	25
1.4	Purchase of Philips I ² C-bus components	3	13.5.3	Timing requirements for the bridge in a mixed-speed bus system	27
2	THE I ² C-BUS BENEFITS DESIGNERS AND MANUFACTURERS	4	14	10-BIT ADDRESSING	27
2.1	Designer benefits	4	14.1	Definition of bits in the first two bytes	27
2.2	Manufacturer benefits	6	14.2	Formats with 10-bit addresses	27
3	INTRODUCTION TO THE I ² C-BUS SPECIFICATION	6	14.3	General call address and start byte with 10-bit addressing	30
4	THE I ² C-BUS CONCEPT	6	15	ELECTRICAL SPECIFICATIONS AND TIMING FOR I/O STAGES AND BUS LINES	30
5	GENERAL CHARACTERISTICS	8	15.1	Standard- and Fast-mode devices	30
6	BIT TRANSFER	8	15.2	Hs-mode devices	34
6.1	Data validity	8	16	ELECTRICAL CONNECTIONS OF I ² C-BUS DEVICES TO THE BUS LINES	37
6.2	START and STOP conditions	9	16.1	Maximum and minimum values of resistors R _p and R _s for Standard-mode I ² C-bus devices	39
7	TRANSFERRING DATA	10	17	APPLICATION INFORMATION	41
7.1	Byte format	10	17.1	Slope-controlled output stages of Fast-mode I ² C-bus devices	41
7.2	Acknowledge	10	17.2	Switched pull-up circuit for Fast-mode I ² C-bus devices	41
8	ARBITRATION AND CLOCK GENERATION	11	17.3	Wiring pattern of the bus lines	42
8.1	Synchronization	11	17.4	Maximum and minimum values of resistors R _p and R _s for Fast-mode I ² C-bus devices	42
8.2	Arbitration	12	17.5	Maximum and minimum values of resistors R _p and R _s for Hs-mode I ² C-bus devices	42
8.3	Use of the clock synchronizing mechanism as a handshake	13	18	BI-DIRECTIONAL LEVEL SHIFTER FOR F/S-MODE I ² C-BUS SYSTEMS	42
9	FORMATS WITH 7-BIT ADDRESSES	13	18.1	Connecting devices with different logic levels	43
10	7-BIT ADDRESSING	15	18.1.1	Operation of the level shifter	44
10.1	Definition of bits in the first byte	15	19	DEVELOPMENT TOOLS AVAILABLE FROM PHILIPS	45
10.1.1	General call address	16	20	SUPPORT LITERATURE	46
10.1.2	START byte	17			
10.1.3	CBUS compatibility	18			
11	EXTENSIONS TO THE STANDARD-MODE I ² C-BUS SPECIFICATION	19			
12	FAST-MODE	19			
13	Hs-MODE	20			
13.1	High speed transfer	20			
13.2	Serial data transfer format in Hs-mode	21			
13.3	Switching from F/S- to Hs-mode and back	23			

The I²C-bus specification

1 PREFACE

1.1 Version 1.0 - 1992

This version of the 1992 I²C-bus specification includes the following modifications:

- Programming of a slave address by software has been omitted. The realization of this feature is rather complicated and has not been used.
- The “low-speed mode” has been omitted. This mode is, in fact, a subset of the total I²C-bus specification and need not be specified explicitly.
- The Fast-mode is added. This allows a fourfold increase of the bit rate up to 400 kbit/s. Fast-mode devices are downwards compatible i.e. they can be used in a 0 to 100 kbit/s I²C-bus system.
- 10-bit addressing is added. This allows 1024 additional slave addresses.
- Slope control and input filtering for Fast-mode devices is specified to improve the EMC behaviour.

NOTE: Neither the 100 kbit/s I²C-bus system nor the 100 kbit/s devices have been changed.

1.2 Version 2.0 - 1998

The I²C-bus has become a de facto world standard that is now implemented in over 1000 different ICs and licensed to more than 50 companies. Many of today's applications, however, require higher bus speeds and lower supply

voltages. This updated version of the I²C-bus specification meets those requirements and includes the following modifications:

- The High-speed mode (Hs-mode) is added. This allows an increase in the bit rate up to 3.4 Mbit/s. Hs-mode devices can be mixed with Fast- and Standard-mode devices on the one I²C-bus system with bit rates from 0 to 3.4 Mbit/s.
- The low output level and hysteresis of devices with a supply voltage of 2 V and below has been adapted to meet the required noise margins and to remain compatible with higher supply voltage devices.
- The 0.6 V at 6 mA requirement for the output stages of Fast-mode devices has been omitted.
- The fixed input levels for new devices are replaced by bus voltage-related levels.
- Application information for bi-directional level shifter is added.

1.3 Version 2.1 - 2000

Version 2.1 of the I²C-bus specification includes the following minor modifications:

- After a repeated START condition in Hs-mode, it is possible to stretch the clock signal SCLH (see Section 13.2 and Figs 22, 25 and 32).
- Some timing parameters in Hs-mode have been relaxed (see Tables 6 and 7).

1.4 Purchase of Philips I²C-bus components



Purchase of Philips I²C components conveys a license under the Philips' I²C patent to use the components in the I²C system provided the system conforms to the I²C specification defined by Philips.

The I²C-bus specification

2 THE I²C-BUS BENEFITS DESIGNERS AND MANUFACTURERS

In consumer electronics, telecommunications and industrial electronics, there are often many similarities between seemingly unrelated designs. For example, nearly every system includes:

- Some intelligent control, usually a single-chip microcontroller
- General-purpose circuits like LCD drivers, remote I/O ports, RAM, EEPROM, or data converters
- Application-oriented circuits such as digital tuning and signal processing circuits for radio and video systems, or DTMF generators for telephones with tone dialling.

To exploit these similarities to the benefit of both systems designers and equipment manufacturers, as well as to maximize hardware efficiency and circuit simplicity, Philips developed a simple bi-directional 2-wire bus for efficient inter-IC control. This bus is called the Inter IC or I²C-bus. At present, Philips' IC range includes more than 150 CMOS and bipolar I²C-bus compatible types for performing functions in all three of the previously mentioned categories. All I²C-bus compatible devices incorporate an on-chip interface which allows them to communicate directly with each other via the I²C-bus. This design concept solves the many interfacing problems encountered when designing digital control circuits.

Here are some of the features of the I²C-bus:

- Only two bus lines are required; a serial data line (SDA) and a serial clock line (SCL)
- Each device connected to the bus is software addressable by a unique address and simple master/slave relationships exist at all times; masters can operate as master-transmitters or as master-receivers
- It's a true multi-master bus including collision detection and arbitration to prevent data corruption if two or more masters simultaneously initiate data transfer
- Serial, 8-bit oriented, bi-directional data transfers can be made at up to 100 kbit/s in the Standard-mode, up to 400 kbit/s in the Fast-mode, or up to 3.4 Mbit/s in the High-speed mode
- On-chip filtering rejects spikes on the bus data line to preserve data integrity

- The number of ICs that can be connected to the same bus is limited only by a maximum bus capacitance of 400 pF.

Figure 1 shows two examples of I²C-bus applications.

2.1 Designer benefits

I²C-bus compatible ICs allow a system design to rapidly progress directly from a functional block diagram to a prototype. Moreover, since they 'clip' directly onto the I²C-bus without any additional external interfacing, they allow a prototype system to be modified or upgraded simply by 'clipping' or 'unclipping' ICs to or from the bus.

Here are some of the features of I²C-bus compatible ICs which are particularly attractive to designers:

- Functional blocks on the block diagram correspond with the actual ICs; designs proceed rapidly from block diagram to final schematic.
- No need to design bus interfaces because the I²C-bus interface is already integrated on-chip.
- Integrated addressing and data-transfer protocol allow systems to be completely software-defined
- The same IC types can often be used in many different applications
- Design-time reduces as designers quickly become familiar with the frequently used functional blocks represented by I²C-bus compatible ICs
- ICs can be added to or removed from a system without affecting any other circuits on the bus
- Fault diagnosis and debugging are simple; malfunctions can be immediately traced
- Software development time can be reduced by assembling a library of reusable software modules.

In addition to these advantages, the CMOS ICs in the I²C-bus compatible range offer designers special features which are particularly attractive for portable equipment and battery-backed systems.

They all have:

- Extremely low current consumption
- High noise immunity
- Wide supply voltage range
- Wide operating temperature range.

The I²C-bus specification

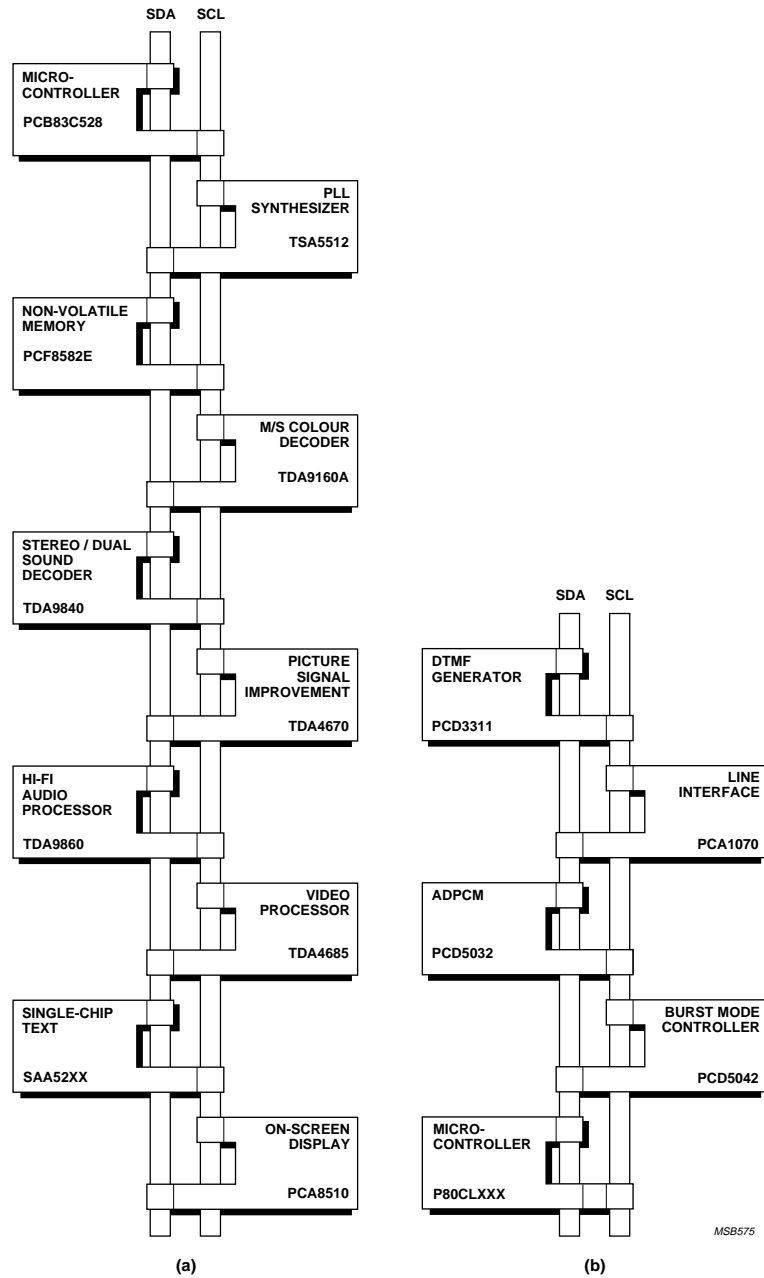

Fig.1 Two examples of I²C-bus applications: (a) a high performance highly-integrated TV set
(b) DECT cordless phone base-station.

The I²C-bus specification

2.2 Manufacturer benefits

I²C-bus compatible ICs don't only assist designers, they also give a wide range of benefits to equipment manufacturers because:

- The simple 2-wire serial I²C-bus minimizes interconnections so ICs have fewer pins and there are not so many PCB tracks; result - smaller and less expensive PCBs
- The completely integrated I²C-bus protocol eliminates the need for address decoders and other 'glue logic'
- The multi-master capability of the I²C-bus allows rapid testing and alignment of end-user equipment via external connections to an assembly-line
- The availability of I²C-bus compatible ICs in SO (small outline), VSO (very small outline) as well as DIL packages reduces space requirements even more.

These are just some of the benefits. In addition, I²C-bus compatible ICs increase system design flexibility by allowing simple construction of equipment variants and easy upgrading to keep designs up-to-date. In this way, an entire family of equipment can be developed around a basic model. Upgrades for new equipment, or enhanced-feature models (i.e. extended memory, remote control, etc.) can then be produced simply by clipping the appropriate ICs onto the bus. If a larger ROM is needed, it's simply a matter of selecting a micro-controller with a larger ROM from our comprehensive range. As new ICs supersede older ones, it's easy to add new features to equipment or to increase its performance by simply unclipping the outdated IC from the bus and clipping on its successor.

3 INTRODUCTION TO THE I²C-BUS SPECIFICATION

For 8-bit oriented digital control applications, such as those requiring microcontrollers, certain design criteria can be established:

- A complete system usually consists of at least one microcontroller and other peripheral devices such as memories and I/O expanders
- The cost of connecting the various devices within the system must be minimized

- A system that performs a control function doesn't require high-speed data transfer
- Overall efficiency depends on the devices chosen and the nature of the interconnecting bus structure.

To produce a system to satisfy these criteria, a serial bus structure is needed. Although serial buses don't have the throughput capability of parallel buses, they do require less wiring and fewer IC connecting pins. However, a bus is not merely an interconnecting wire, it embodies all the formats and procedures for communication within the system.

Devices communicating with each other on a serial bus must have some form of protocol which avoids all possibilities of confusion, data loss and blockage of information. Fast devices must be able to communicate with slow devices. The system must not be dependent on the devices connected to it, otherwise modifications or improvements would be impossible. A procedure has also to be devised to decide which device will be in control of the bus and when. And, if different devices with different clock speeds are connected to the bus, the bus clock source must be defined. All these criteria are involved in the specification of the I²C-bus.

4 THE I²C-BUS CONCEPT

The I²C-bus supports any IC fabrication process (NMOS, CMOS, bipolar). Two wires, serial data (SDA) and serial clock (SCL), carry information between the devices connected to the bus. Each device is recognized by a unique address (whether it's a microcontroller, LCD driver, memory or keyboard interface) and can operate as either a transmitter or receiver, depending on the function of the device. Obviously an LCD driver is only a receiver, whereas a memory can both receive and transmit data. In addition to transmitters and receivers, devices can also be considered as masters or slaves when performing data transfers (see Table 1). A master is the device which initiates a data transfer on the bus and generates the clock signals to permit that transfer. At that time, any device addressed is considered a slave.

The I²C-bus specification

Table 1 Definition of I²C-bus terminology

TERM	DESCRIPTION
Transmitter	The device which sends data to the bus
Receiver	The device which receives data from the bus
Master	The device which initiates a transfer, generates clock signals and terminates a transfer
Slave	The device addressed by a master
Multi-master	More than one master can attempt to control the bus at the same time without corrupting the message
Arbitration	Procedure to ensure that, if more than one master simultaneously tries to control the bus, only one is allowed to do so and the winning message is not corrupted
Synchronization	Procedure to synchronize the clock signals of two or more devices

The I²C-bus is a multi-master bus. This means that more than one device capable of controlling the bus can be connected to it. As masters are usually micro-controllers, let's consider the case of a data transfer between two microcontrollers connected to the I²C-bus (see Fig.2).

This highlights the master-slave and receiver-transmitter relationships to be found on the I²C-bus. It should be noted that these relationships are not permanent, but only depend on the direction of data transfer at that time. The transfer of data would proceed as follows:

1) Suppose microcontroller A wants to send information to microcontroller B:

- microcontroller A (master), addresses microcontroller B (slave)
- microcontroller A (master-transmitter), sends data to microcontroller B (slave- receiver)
- microcontroller A terminates the transfer

2) If microcontroller A wants to receive information from microcontroller B:

- microcontroller A (master) addresses microcontroller B (slave)
- microcontroller A (master- receiver) receives data from microcontroller B (slave- transmitter)
- microcontroller A terminates the transfer.

Even in this case, the master (microcontroller A) generates the timing and terminates the transfer.

The possibility of connecting more than one microcontroller to the I²C-bus means that more than one master could try to initiate a data transfer at the same time. To avoid the chaos that might ensue from such an event - an arbitration procedure has been developed. This procedure relies on the wired-AND connection of all I²C interfaces to the I²C-bus.

If two or more masters try to put information onto the bus, the first to produce a 'one' when the other produces a 'zero' will lose the arbitration. The clock signals during arbitration are a synchronized combination of the clocks generated by the masters using the wired-AND connection to the SCL line (for more detailed information concerning arbitration see Section 8).

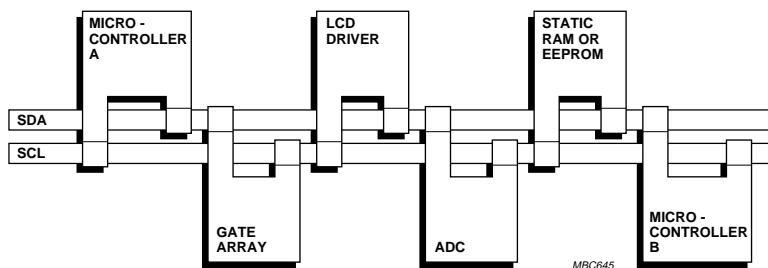

Fig.2 Example of an I²C-bus configuration using two microcontrollers.

The I²C-bus specification

Generation of clock signals on the I²C-bus is always the responsibility of master devices; each master generates its own clock signals when transferring data on the bus. Bus clock signals from a master can only be altered when they are stretched by a slow-slave device holding-down the clock line, or by another master when arbitration occurs.

5 GENERAL CHARACTERISTICS

Both SDA and SCL are bi-directional lines, connected to a positive supply voltage via a current-source or pull-up resistor (see Fig.3). When the bus is free, both lines are HIGH. The output stages of devices connected to the bus must have an open-drain or open-collector to perform the wired-AND function. Data on the I²C-bus can be transferred at rates of up to 100 kbit/s in the Standard-mode, up to 400 kbit/s in the Fast-mode, or up to 3.4 Mbit/s in the High-speed mode. The number of interfaces connected to the bus is solely dependent on the bus capacitance limit of 400 pF. For information on High-speed mode master devices, see Section 13.

6 BIT TRANSFER

Due to the variety of different technology devices (CMOS, NMOS, bipolar) which can be connected to the I²C-bus, the levels of the logical '0' (LOW) and '1' (HIGH) are not fixed and depend on the associated level of V_{DD} (see Section 15 for electrical specifications). One clock pulse is generated for each data bit transferred.

6.1 Data validity

The data on the SDA line must be stable during the HIGH period of the clock. The HIGH or LOW state of the data line can only change when the clock signal on the SCL line is LOW (see Fig.4).

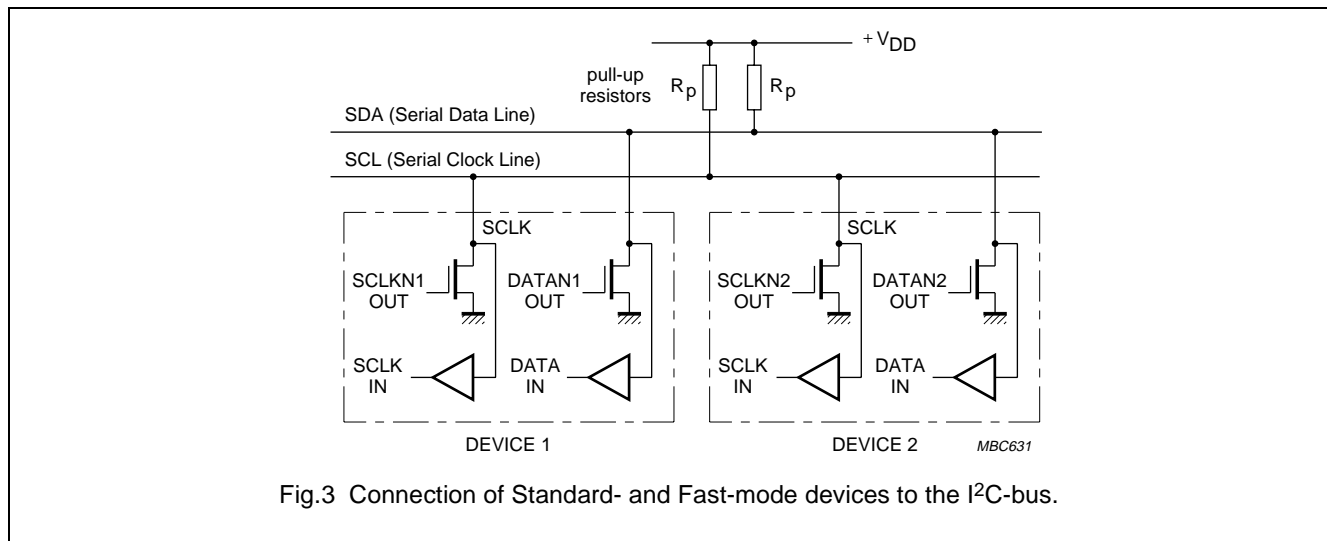

The I²C-bus specification

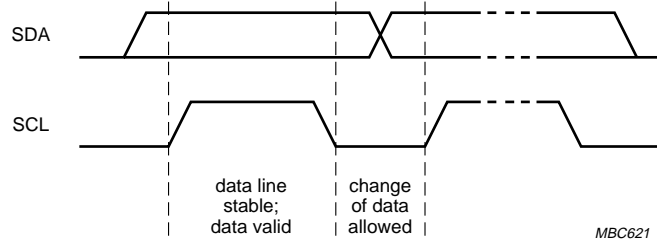

Fig.4 Bit transfer on the I²C-bus.

6.2 START and STOP conditions

Within the procedure of the I²C-bus, unique situations arise which are defined as START (S) and STOP (P) conditions (see Fig.5).

A HIGH to LOW transition on the SDA line while SCL is HIGH is one such unique case. This situation indicates a START condition.

A LOW to HIGH transition on the SDA line while SCL is HIGH defines a STOP condition.

START and STOP conditions are always generated by the master. The bus is considered to be busy after the START condition. The bus is considered to be free again a certain time after the STOP condition. This bus free situation is specified in Section 15.

The bus stays busy if a repeated START (Sr) is generated instead of a STOP condition. In this respect, the START (S) and repeated START (Sr) conditions are functionally identical (see Fig. 10). For the remainder of this document, therefore, the S symbol will be used as a generic term to represent both the START and repeated START conditions, unless Sr is particularly relevant.

Detection of START and STOP conditions by devices connected to the bus is easy if they incorporate the necessary interfacing hardware. However, microcontrollers with no such interface have to sample the SDA line at least twice per clock period to sense the transition.

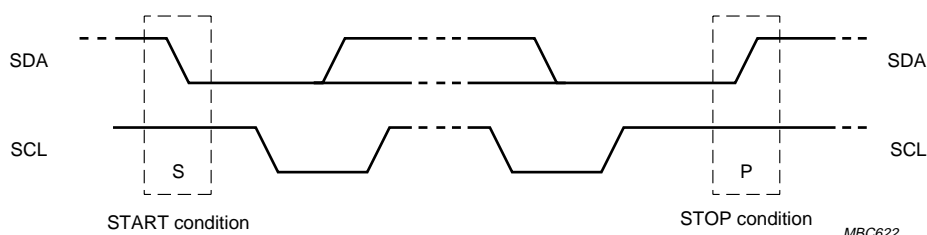

Fig.5 START and STOP conditions.

The I²C-bus specification

7 TRANSFERRING DATA

7.1 Byte format

Every byte put on the SDA line must be 8-bits long. The number of bytes that can be transmitted per transfer is unrestricted. Each byte has to be followed by an acknowledge bit. Data is transferred with the most significant bit (MSB) first (see Fig.6). If a slave can't receive or transmit another complete byte of data until it has performed some other function, for example servicing an internal interrupt, it can hold the clock line SCL LOW to force the master into a wait state. Data transfer then continues when the slave is ready for another byte of data and releases clock line SCL.

In some cases, it's permitted to use a different format from the I²C-bus format (for CBUS compatible devices for example). A message which starts with such an address can be terminated by generation of a STOP condition, even during the transmission of a byte. In this case, no acknowledge is generated (see Section 10.1.3).

7.2 Acknowledge

Data transfer with acknowledge is obligatory. The acknowledge-related clock pulse is generated by the master. The transmitter releases the SDA line (HIGH) during the acknowledge clock pulse.

The receiver must pull down the SDA line during the acknowledge clock pulse so that it remains stable LOW

during the HIGH period of this clock pulse (see Fig.7). Of course, set-up and hold times (specified in Section 15) must also be taken into account.

Usually, a receiver which has been addressed is obliged to generate an acknowledge after each byte has been received, except when the message starts with a CBUS address (see Section 10.1.3).

When a slave doesn't acknowledge the slave address (for example, it's unable to receive or transmit because it's performing some real-time function), the data line must be left HIGH by the slave. The master can then generate either a STOP condition to abort the transfer, or a repeated START condition to start a new transfer.

If a slave-receiver does acknowledge the slave address but, some time later in the transfer cannot receive any more data bytes, the master must again abort the transfer. This is indicated by the slave generating the not-acknowledge on the first byte to follow. The slave leaves the data line HIGH and the master generates a STOP or a repeated START condition.

If a master-receiver is involved in a transfer, it must signal the end of data to the slave- transmitter by not generating an acknowledge on the last byte that was clocked out of the slave. The slave-transmitter must release the data line to allow the master to generate a STOP or repeated START condition.

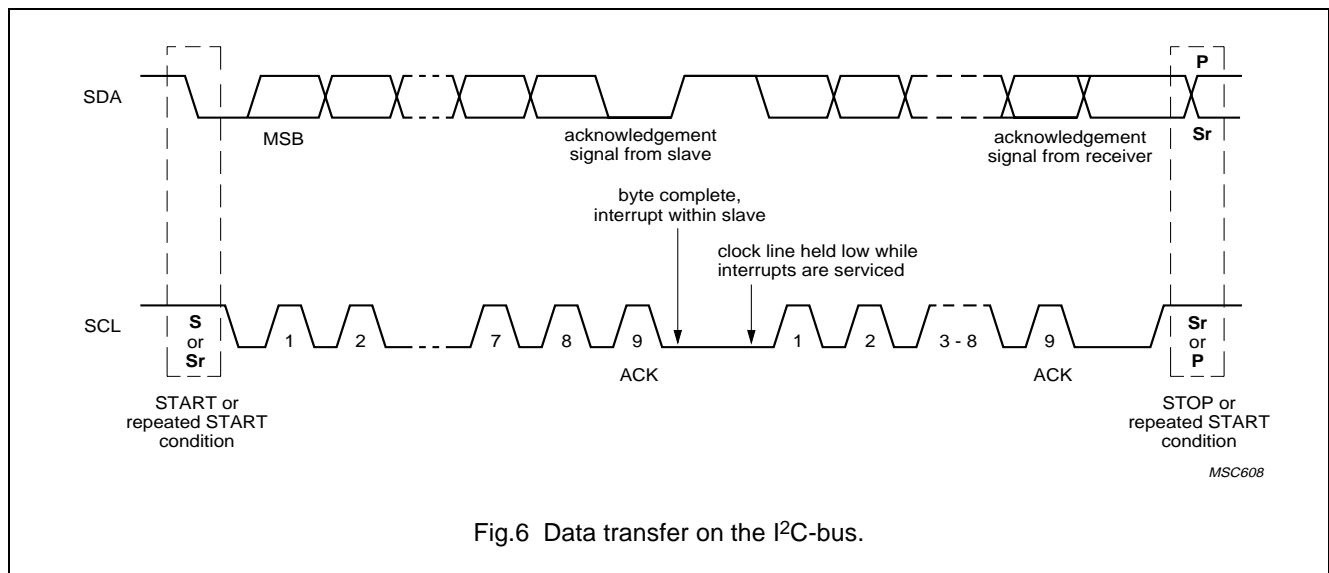
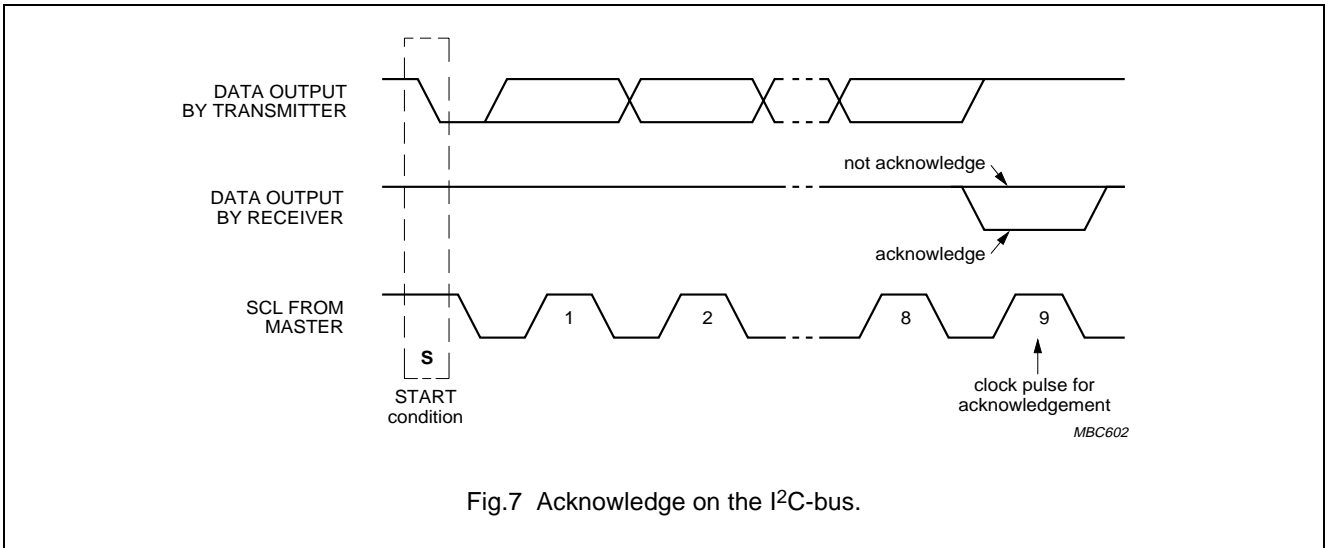

Fig.6 Data transfer on the I²C-bus.

The I²C-bus specification



8 ARBITRATION AND CLOCK GENERATION

8.1 Synchronization

All masters generate their own clock on the SCL line to transfer messages on the I²C-bus. Data is only valid during the HIGH period of the clock. A defined clock is therefore needed for the bit-by-bit arbitration procedure to take place.

Clock synchronization is performed using the wired-AND connection of I²C interfaces to the SCL line. This means

that a HIGH to LOW transition on the SCL line will cause the devices concerned to start counting off their LOW period and, once a device clock has gone LOW, it will hold the SCL line in that state until the clock HIGH state is reached (see Fig.8). However, the LOW to HIGH transition of this clock may not change the state of the SCL line if another clock is still within its LOW period. The SCL line will therefore be held LOW by the device with the longest LOW period. Devices with shorter LOW periods enter a HIGH wait-state during this time.

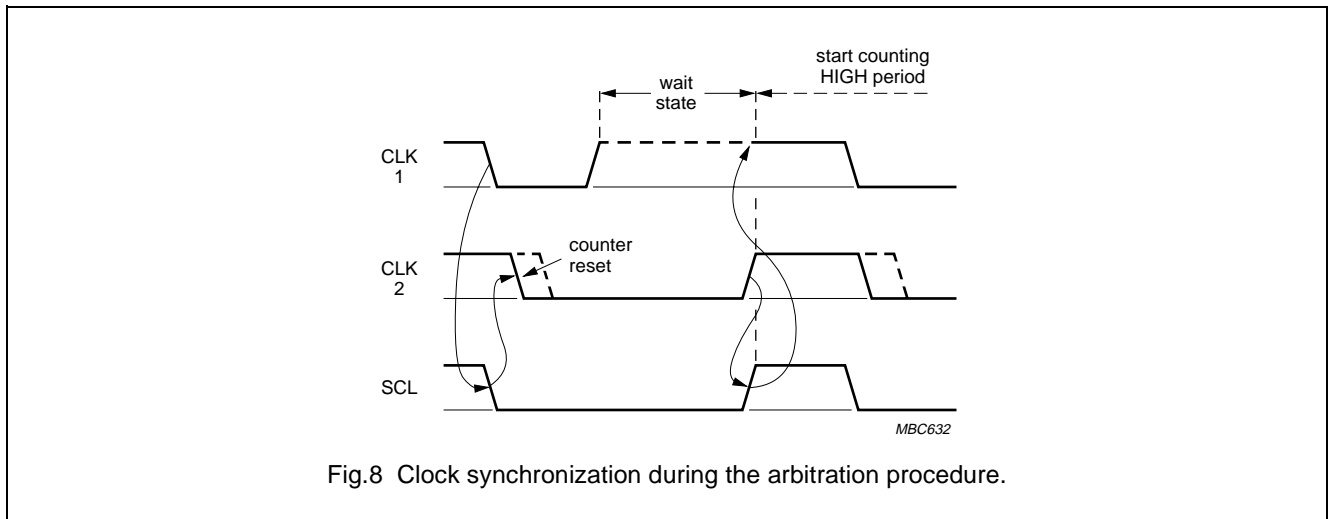

The I²C-bus specification

When all devices concerned have counted off their LOW period, the clock line will be released and go HIGH. There will then be no difference between the device clocks and the state of the SCL line, and all the devices will start counting their HIGH periods. The first device to complete its HIGH period will again pull the SCL line LOW.

In this way, a synchronized SCL clock is generated with its LOW period determined by the device with the longest clock LOW period, and its HIGH period determined by the one with the shortest clock HIGH period.

8.2 Arbitration

A master may start a transfer only if the bus is free. Two or more masters may generate a START condition within the minimum hold time ($t_{HD,STA}$) of the START condition which results in a defined START condition to the bus.

Arbitration takes place on the SDA line, while the SCL line is at the HIGH level, in such a way that the master which transmits a HIGH level, while another master is transmitting a LOW level will switch off its DATA output stage because the level on the bus doesn't correspond to its own level.

Arbitration can continue for many bits. Its first stage is comparison of the address bits (addressing information is given in Sections 10 and 14). If the masters are each trying

to address the same device, arbitration continues with comparison of the data-bits if they are master-transmitter, or acknowledge-bits if they are master-receiver. Because address and data information on the I²C-bus is determined by the winning master, no information is lost during the arbitration process.

A master that loses the arbitration can generate clock pulses until the end of the byte in which it loses the arbitration.

As an Hs-mode master has a unique 8-bit master code, it will always finish the arbitration during the first byte (see Section 13).

If a master also incorporates a slave function and it loses arbitration during the addressing stage, it's possible that the winning master is trying to address it. The losing master must therefore switch over immediately to its slave mode.

Figure 9 shows the arbitration procedure for two masters. Of course, more may be involved (depending on how many masters are connected to the bus). The moment there is a difference between the internal data level of the master generating DATA 1 and the actual level on the SDA line, its data output is switched off, which means that a HIGH output level is then connected to the bus. This will not affect the data transfer initiated by the winning master.

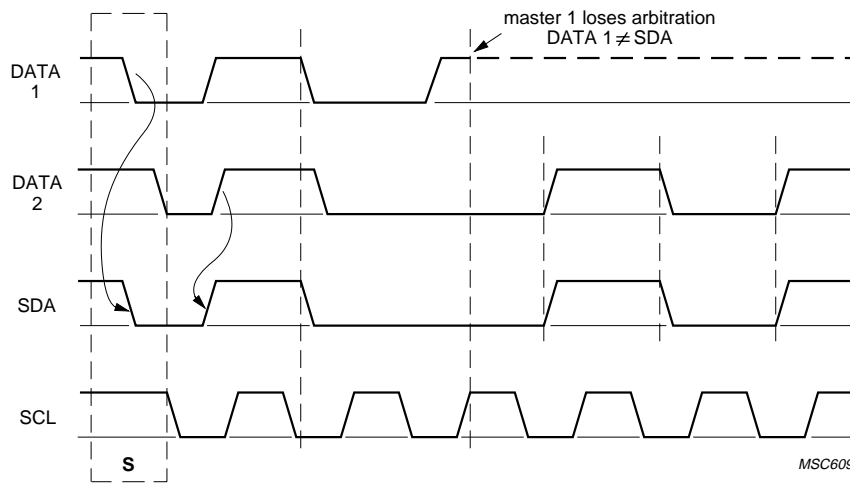

Fig.9 Arbitration procedure of two masters.

The I²C-bus specification

Since control of the I²C-bus is decided solely on the address or master code and data sent by competing masters, there is no central master, nor any order of priority on the bus.

Special attention must be paid if, during a serial transfer, the arbitration procedure is still in progress at the moment when a repeated START condition or a STOP condition is transmitted to the I²C-bus. If it's possible for such a situation to occur, the masters involved must send this repeated START condition or STOP condition at the same position in the format frame. In other words, arbitration isn't allowed between:

- A repeated START condition and a data bit
- A STOP condition and a data bit
- A repeated START condition and a STOP condition.

Slaves are not involved in the arbitration procedure.

8.3 Use of the clock synchronizing mechanism as a handshake

In addition to being used during the arbitration procedure, the clock synchronization mechanism can be used to enable receivers to cope with fast data transfers, on either a byte level or a bit level.

On the byte level, a device may be able to receive bytes of data at a fast rate, but needs more time to store a received byte or prepare another byte to be transmitted. Slaves can

then hold the SCL line LOW after reception and acknowledgment of a byte to force the master into a wait state until the slave is ready for the next byte transfer in a type of handshake procedure (see Fig.6).

On the bit level, a device such as a microcontroller with or without limited hardware for the I²C-bus, can slow down the bus clock by extending each clock LOW period. The speed of any master is thereby adapted to the internal operating rate of this device.

In Hs-mode, this handshake feature can only be used on byte level (see Section 13).

9 FORMATS WITH 7-BIT ADDRESSES

Data transfers follow the format shown in Fig.10. After the START condition (S), a slave address is sent. This address is 7 bits long followed by an eighth bit which is a data direction bit (R/W) - a 'zero' indicates a transmission (WRITE), a 'one' indicates a request for data (READ). A data transfer is always terminated by a STOP condition (P) generated by the master. However, if a master still wishes to communicate on the bus, it can generate a repeated START condition (Sr) and address another slave without first generating a STOP condition. Various combinations of read/write formats are then possible within such a transfer.

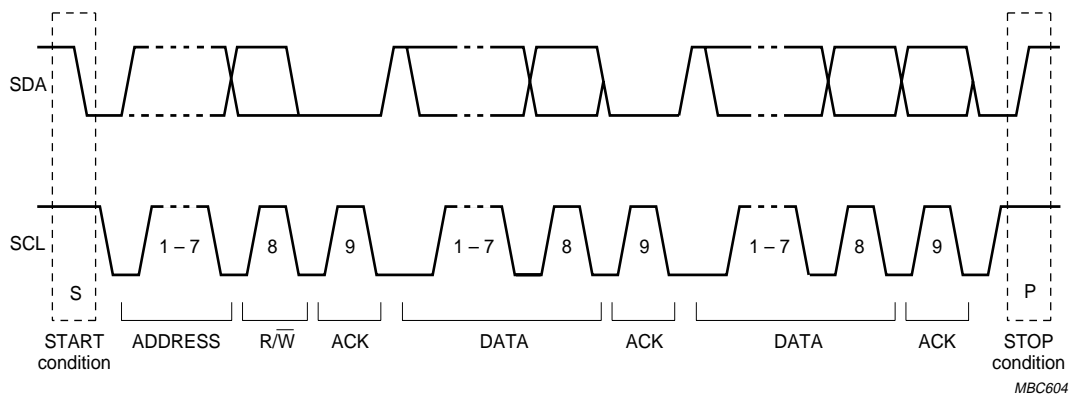

Fig.10 A complete data transfer.

The I²C-bus specification

Possible data transfer formats are:

- Master-transmitter transmits to slave-receiver. The transfer direction is not changed (see Fig.11).
- Master reads slave immediately after first byte (see Fig.12). At the moment of the first acknowledge, the master-transmitter becomes a master-receiver and the slave-receiver becomes a slave-transmitter. This first acknowledge is still generated by the slave. The STOP condition is generated by the master, which has previously sent a not-acknowledge (\bar{A}).
- Combined format (see Fig.13). During a change of direction within a transfer, the START condition and the slave address are both repeated, but with the R/W bit reversed. If a master receiver sends a repeated START condition, it has previously sent a not-acknowledge (\bar{A}).

NOTES:

1. Combined formats can be used, for example, to control a serial memory. During the first data byte, the internal memory location has to be written. After the START condition and slave address is repeated, data can be transferred.
2. All decisions on auto-increment or decrement of previously accessed memory locations etc. are taken by the designer of the device.
3. Each byte is followed by an acknowledgment bit as indicated by the A or \bar{A} blocks in the sequence.
4. I²C-bus compatible devices must reset their bus logic on receipt of a START or repeated START condition such that they all anticipate the sending of a slave address, even if these START conditions are not positioned according to the proper format.
5. A START condition immediately followed by a STOP condition (void message) is an illegal format.

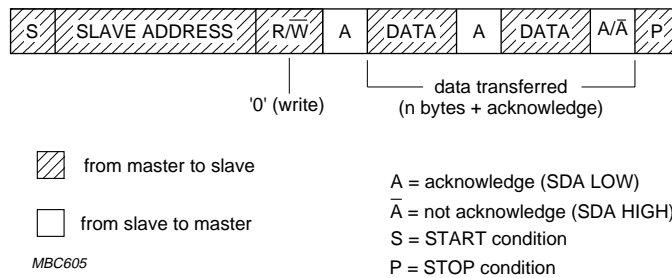

Fig.11 A master-transmitter addressing a slave receiver with a 7-bit address. The transfer direction is not changed.

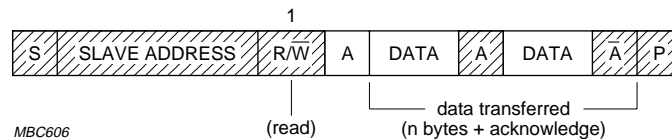

Fig.12 A master reads a slave immediately after the first byte.

The I²C-bus specification

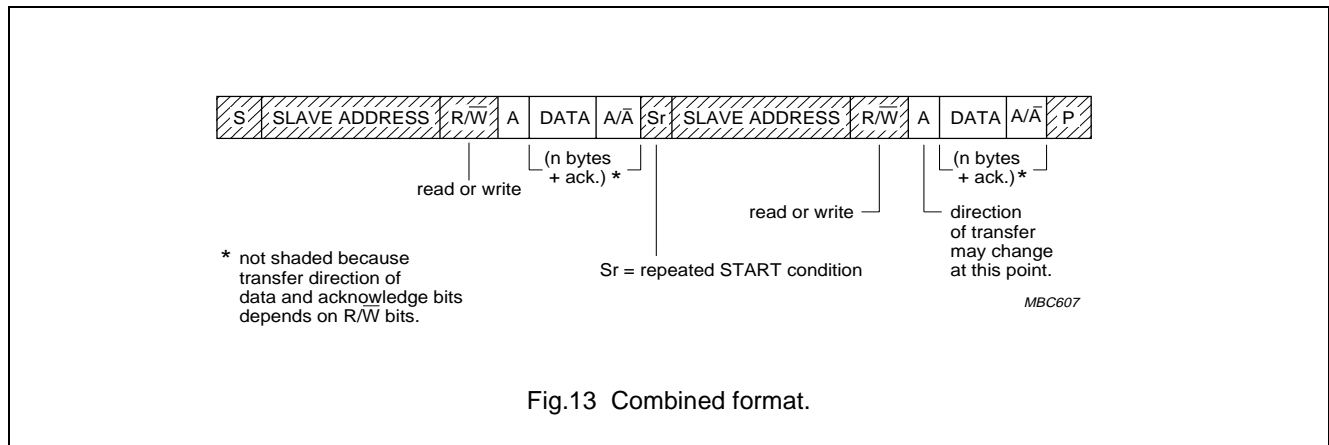

Fig.13 Combined format.

10 7-BIT ADDRESSING

The addressing procedure for the I²C-bus is such that the first byte after the START condition usually determines which slave will be selected by the master. The exception is the 'general call' address which can address all devices. When this address is used, all devices should, in theory, respond with an acknowledge. However, devices can be made to ignore this address. The second byte of the general call address then defines the action to be taken. This procedure is explained in more detail in Section 10.1.1. For information on 10-bit addressing, see Section 14

10.1 Definition of bits in the first byte

The first seven bits of the first byte make up the slave address (see Fig.14). The eighth bit is the LSB (least significant bit). It determines the direction of the message. A 'zero' in the least significant position of the first byte means that the master will write information to a selected slave. A 'one' in this position means that the master will read information from the slave.

When an address is sent, each device in a system compares the first seven bits after the START condition with its address. If they match, the device considers itself addressed by the master as a slave-receiver or slave-transmitter, depending on the R/W bit.

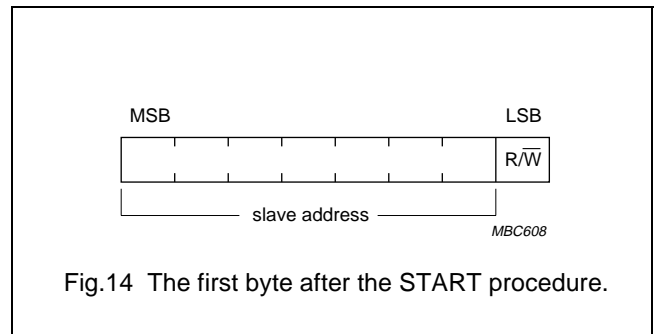

Fig.14 The first byte after the START procedure.

A slave address can be made-up of a fixed and a programmable part. Since it's likely that there will be several identical devices in a system, the programmable part of the slave address enables the maximum possible number of such devices to be connected to the I²C-bus. The number of programmable address bits of a device depends on the number of pins available. For example, if a device has 4 fixed and 3 programmable address bits, a total of 8 identical devices can be connected to the same bus.

The I²C-bus committee coordinates allocation of I²C addresses. Further information can be obtained from the Philips representatives listed on the back cover. Two groups of eight addresses (0000XXX and 1111XXX) are reserved for the purposes shown in Table 2. The bit combination 11110XX of the slave address is reserved for 10-bit addressing (see Section 14).

The I²C-bus specification

Table 2 Definition of bits in the first byte

SLAVE ADDRESS	R/W BIT	DESCRIPTION
0000 000	0	General call address
0000 000	1	START byte ⁽¹⁾
0000 001	X	CBUS address ⁽²⁾
0000 010	X	Reserved for different bus format ⁽³⁾
0000 011	X	Reserved for future purposes
0000 1XX	X	Hs-mode master code
1111 1XX	X	Reserved for future purposes
1111 0XX	X	10-bit slave addressing

Notes

- No device is allowed to acknowledge at the reception of the START byte.
- The CBUS address has been reserved to enable the inter-mixing of CBUS compatible and I²C-bus compatible devices in the same system. I²C-bus compatible devices are not allowed to respond on reception of this address.
- The address reserved for a different bus format is included to enable I²C and other protocols to be mixed. Only I²C-bus compatible devices that can work with such formats and protocols are allowed to respond to this address.

10.1.1 GENERAL CALL ADDRESS

The general call address is for addressing every device connected to the I²C-bus. However, if a device doesn't need any of the data supplied within the general call structure, it can ignore this address by not issuing an acknowledgment. If a device does require data from a general call address, it will acknowledge this address and behave as a slave- receiver. The second and following bytes will be acknowledged by every slave- receiver capable of handling this data. A slave which cannot process one of these bytes must ignore it by not-acknowledging. The meaning of the general call address is always specified in the second byte (see Fig.15).

There are two cases to consider:

- When the least significant bit B is a 'zero'.
- When the least significant bit B is a 'one'.

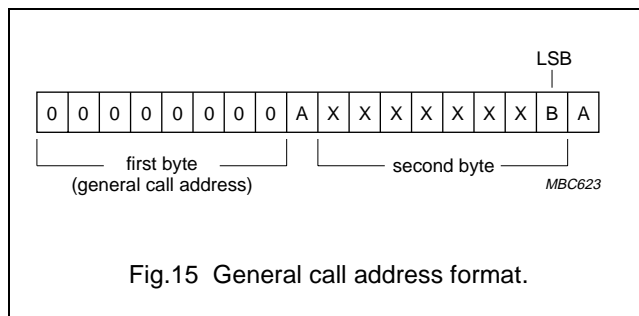

Fig.15 General call address format.

When bit B is a 'zero'; the second byte has the following definition:

- 00000110 (H'06'). Reset and write programmable part of slave address by hardware. On receiving this 2-byte sequence, all devices designed to respond to the general call address will reset and take in the programmable part of their address. Pre-cautions have to be taken to ensure that a device is not pulling down the SDA or SCL line after applying the supply voltage, since these low levels would block the bus.
- 00000100 (H'04'). Write programmable part of slave address by hardware. All devices which define the programmable part of their address by hardware (and which respond to the general call address) will latch this programmable part at the reception of this two byte sequence. The device will not reset.
- 00000000 (H'00'). This code is not allowed to be used as the second byte.

Sequences of programming procedure are published in the appropriate device data sheets.

The remaining codes have not been fixed and devices must ignore them.

When bit B is a 'one'; the 2-byte sequence is a 'hardware general call'. This means that the sequence is transmitted by a hardware master device, such as a keyboard scanner, which cannot be programmed to transmit a desired slave address. Since a hardware master doesn't know in advance to which device the message has to be transferred, it can only generate this hardware general call and its own address - identifying itself to the system (see Fig.16).

The seven bits remaining in the second byte contain the address of the hardware master. This address is recognized by an intelligent device (e.g. a microcontroller) connected to the bus which will then direct the information from the hardware master. If the hardware master can also act as a slave, the slave address is identical to the master address.

The I²C-bus specification

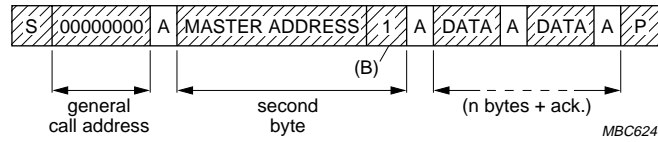

Fig.16 Data transfer from a hardware master-transmitter.

In some systems, an alternative could be that the hardware master transmitter is set in the slave-receiver mode after the system reset. In this way, a system configuring master can tell the hardware master-transmitter (which is now in slave-receiver mode) to which address data must be sent (see Fig.17). After this programming procedure, the hardware master remains in the master-transmitter mode.

10.1.2 START BYTE

Microcontrollers can be connected to the I²C-bus in two ways. A microcontroller with an on-chip hardware I²C-bus interface can be programmed to be only interrupted by requests from the bus. When the device doesn't have such

an interface, it must constantly monitor the bus via software. Obviously, the more times the microcontroller monitors, or polls the bus, the less time it can spend carrying out its intended function.

There is therefore a speed difference between fast hardware devices and a relatively slow microcontroller which relies on software polling.

In this case, data transfer can be preceded by a start procedure which is much longer than normal (see Fig.18). The start procedure consists of:

- A START condition (S)
- A START byte (00000001)
- An acknowledge clock pulse (ACK)
- A repeated START condition (Sr).

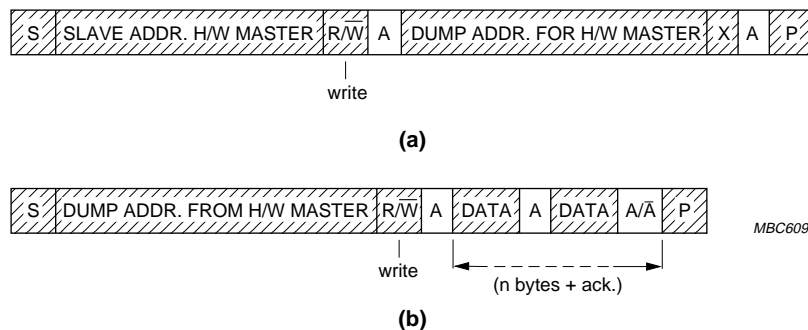

Fig.17 Data transfer by a hardware-transmitter capable of dumping data directly to slave devices.

- (a) Configuring master sends dump address to hardware master
- (b) Hardware master dumps data to selected slave.

The I²C-bus specification

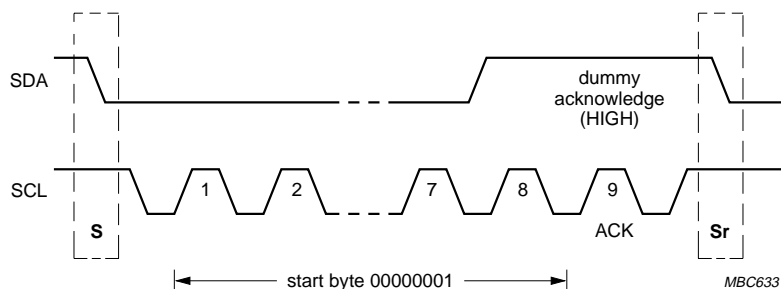

Fig.18 START byte procedure.

After the START condition S has been transmitted by a master which requires bus access, the START byte (00000001) is transmitted. Another microcontroller can therefore sample the SDA line at a low sampling rate until one of the seven zeros in the START byte is detected. After detection of this LOW level on the SDA line, the microcontroller can switch to a higher sampling rate to find the repeated START condition Sr which is then used for synchronization.

A hardware receiver will reset on receipt of the repeated START condition Sr and will therefore ignore the START byte.

An acknowledge-related clock pulse is generated after the START byte. This is present only to conform with the byte handling format used on the bus. No device is allowed to acknowledge the START byte.

10.1.3 CBUS COMPATIBILITY

CBUS receivers can be connected to the Standard-mode I²C-bus. However, a third bus line called DLEN must then be connected and the acknowledge bit omitted. Normally, I²C transmissions are sequences of 8-bit bytes; CBUS compatible devices have different formats.

In a mixed bus structure, I²C-bus devices must not respond to the CBUS message. For this reason, a special CBUS address (0000001X) to which no I²C-bus compatible device will respond, has been reserved. After transmission of the CBUS address, the DLEN line can be made active and a CBUS-format transmission sent (see Fig.19). After the STOP condition, all devices are again ready to accept data.

Master-transmitters can send CBUS formats after sending the CBUS address. The transmission is ended by a STOP condition, recognized by all devices.

NOTE: If the CBUS configuration is known, and expansion with CBUS compatible devices isn't foreseen, the designer is allowed to adapt the hold time to the specific requirements of the device(s) used.

The I²C-bus specification

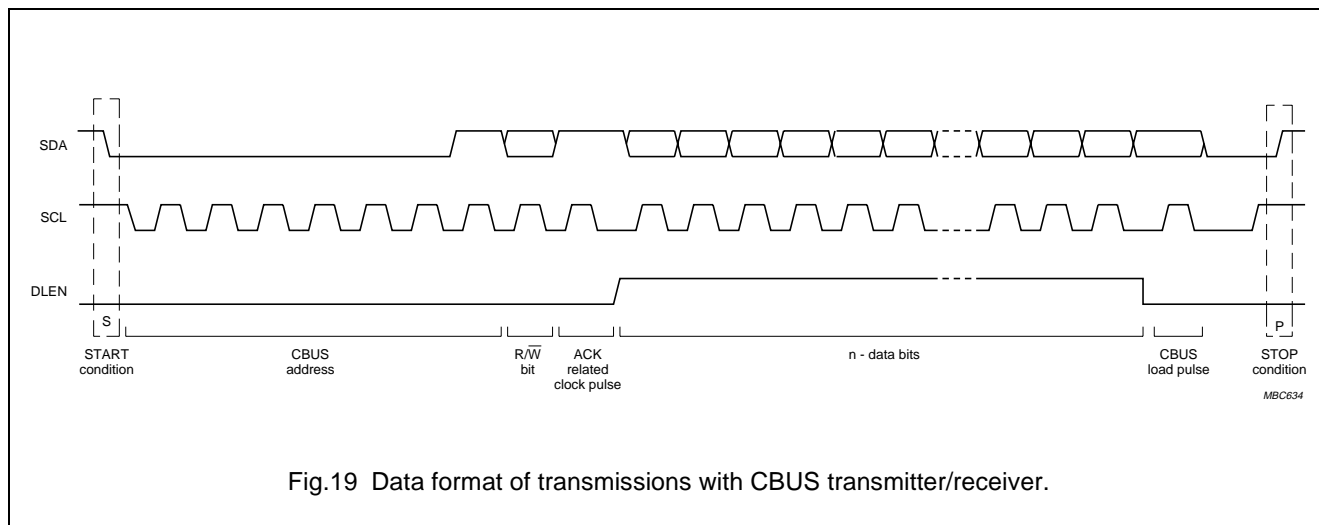

Fig.19 Data format of transmissions with CBUS transmitter/receiver.

11 EXTENSIONS TO THE STANDARD-MODE I²C-BUS SPECIFICATION

The Standard-mode I²C-bus specification, with its data transfer rate of up to 100 kbit/s and 7-bit addressing, has been in existence since the beginning of the 1980's. This concept rapidly grew in popularity and is today accepted worldwide as a de facto standard with several hundred different compatible ICs on offer from Philips Semiconductors and other suppliers. To meet the demands for higher speeds, as well as make available more slave address for the growing number of new devices, the Standard-mode I²C-bus specification was upgraded over the years and today is available with the following extensions:

- **Fast-mode**, with a bit rate up to 400 kbit/s.
- **High-speed mode (Hs-mode)**, with a bit rate up to 3.4 Mbit/s.
- **10-bit addressing**, which allows the use of up to 1024 additional slave addresses.

There are two main reasons for extending the regular I²C-bus specification:

- Many of today's applications need to transfer large amounts of serial data and require bit rates far in excess of 100 kbit/s (Standard-mode), or even 400 kbit/s (Fast-mode). As a result of continuing improvements in semiconductor technologies, I²C-bus devices are now available with bit rates of up to 3.4 Mbit/s (Hs-mode) without any noticeable increases in the manufacturing cost of the interface circuitry.
- As most of the 112 addresses available with the 7-bit addressing scheme were soon allocated, it became

apparent that more address combinations were required to prevent problems with the allocation of slave addresses for new devices. This problem was resolved with the new 10-bit addressing scheme, which allowed about a tenfold increase in available addresses.

New slave devices with a Fast- or Hs-mode I²C-bus interface can have a 7- or a 10-bit slave address. If possible, a 7-bit address is preferred as it is the cheapest hardware solution and results in the shortest message length. Devices with 7- and 10-bit addresses can be mixed in the same I²C-bus system regardless of whether it is an F/S- or Hs-mode system. Both existing and future masters can generate either 7- or 10-bit addresses.

12 FAST-MODE

With the Fast-mode I²C-bus specification, the protocol, format, logic levels and maximum capacitive load for the SDA and SCL lines quoted in the Standard-mode I²C-bus specification are unchanged. New devices with an I²C-bus interface must meet at least the minimum requirements of the Fast- or Hs-mode specification (see Section 13).

Fast-mode devices can receive and transmit at up to 400 kbit/s. The minimum requirement is that they can synchronize with a 400 kbit/s transfer; they can then prolong the LOW period of the SCL signal to slow down the transfer. Fast-mode devices are downward-compatible and can communicate with Standard-mode devices in a 0 to 100 kbit/s I²C-bus system. As Standard-mode devices, however, are not upward compatible, they should not be incorporated in a Fast-mode I²C-bus system as they cannot follow the higher transfer rate and unpredictable states would occur.

The I²C-bus specification

The Fast-mode I²C-bus specification has the following additional features compared with the Standard-mode:

- The maximum bit rate is increased to 400 kbit/s.
- Timing of the serial data (SDA) and serial clock (SCL) signals has been adapted. There is no need for compatibility with other bus systems such as CBUS because they cannot operate at the increased bit rate.
- The inputs of Fast-mode devices incorporate spike suppression and a Schmitt trigger at the SDA and SCL inputs.
- The output buffers of Fast-mode devices incorporate slope control of the falling edges of the SDA and SCL signals.
- If the power supply to a Fast-mode device is switched off, the SDA and SCL I/O pins must be floating so that they don't obstruct the bus lines.
- The external pull-up devices connected to the bus lines must be adapted to accommodate the shorter maximum permissible rise time for the Fast-mode I²C-bus. For bus loads up to 200 pF, the pull-up device for each bus line can be a resistor; for bus loads between 200 pF and 400 pF, the pull-up device can be a current source (3 mA max.) or a switched resistor circuit (see Fig.43).

13 Hs-MODE

High-speed mode (Hs-mode) devices offer a quantum leap in I²C-bus transfer speeds. Hs-mode devices can transfer information at bit rates of up to 3.4 Mbit/s, yet they remain fully downward compatible with Fast- or Standard-mode (F/S-mode) devices for bi-directional communication in a mixed-speed bus system. With the exception that arbitration and clock synchronization is not performed during the Hs-mode transfer, the same serial bus protocol and data format is maintained as with the F/S-mode system. Depending on the application, new devices may have a Fast or Hs-mode I²C-bus interface, although Hs-mode devices are preferred as they can be designed-in to a greater number of applications.

13.1 High speed transfer

To achieve a bit transfer of up to 3.4 Mbit/s the following improvements have been made to the regular I²C-bus specification:

- Hs-mode master devices have an open-drain output buffer for the SDAH signal and a combination of an open-drain pull-down and current-source pull-up circuit on the SCLH output⁽¹⁾. This current-source circuit shortens the rise time of the SCLH signal. Only the

current-source of one master is enabled at any one time, and only during Hs-mode.

- No arbitration or clock synchronization is performed during Hs-mode transfer in multi-master systems, which speeds-up bit handling capabilities. The arbitration procedure always finishes after a preceding master code transmission in F/S-mode.
- Hs-mode master devices generate a serial clock signal with a HIGH to LOW ratio of 1 to 2. This relieves the timing requirements for set-up and hold times.
- As an option, Hs-mode master devices can have a built-in bridge⁽¹⁾. During Hs-mode transfer, the high speed data (SDAH) and high-speed serial clock (SCLH) lines of Hs-mode devices are separated by this bridge from the SDA and SCL lines of F/S-mode devices. This reduces the capacitive load of the SDAH and SCLH lines resulting in faster rise and fall times.
- The only difference between Hs-mode slave devices and F/S-mode slave devices is the speed at which they operate. Hs-mode slaves have open-drain output buffers on the SCLH and SDAH outputs. Optional pull-down transistors on the SCLH pin can be used to stretch the LOW level of the SCLH signal, although this is only allowed after the acknowledge bit in Hs-mode transfers.
- The inputs of Hs-mode devices incorporate spike suppression and a Schmitt trigger at the SDAH and SCLH inputs.
- The output buffers of Hs-mode devices incorporate slope control of the falling edges of the SDAH and SCLH signals.

Figure 20 shows the physical I²C-bus configuration in a system with only Hs-mode devices. Pins SDA and SCL on the master devices are only used in mixed-speed bus systems and are not connected in an Hs-mode only system. In such cases, these pins can be used for other functions.

Optional series resistors R_s protect the I/O stages of the I²C-bus devices from high-voltage spikes on the bus lines and minimize ringing and interference.

Pull-up resistors R_p maintain the SDAH and SCLH lines at a HIGH level when the bus is free and ensure the signals are pulled up from a LOW to a HIGH level within the required rise time. For higher capacitive bus-line loads (>100 pF), the resistor R_p can be replaced by external current source pull-ups to meet the rise time requirements. Unless preceded by an acknowledge bit, the rise time of the SCLH clock pulses in Hs-mode transfers is shortened by the internal current-source pull-up circuit MCS of the active master.

(1) Patent application pending.

The I²C-bus specification

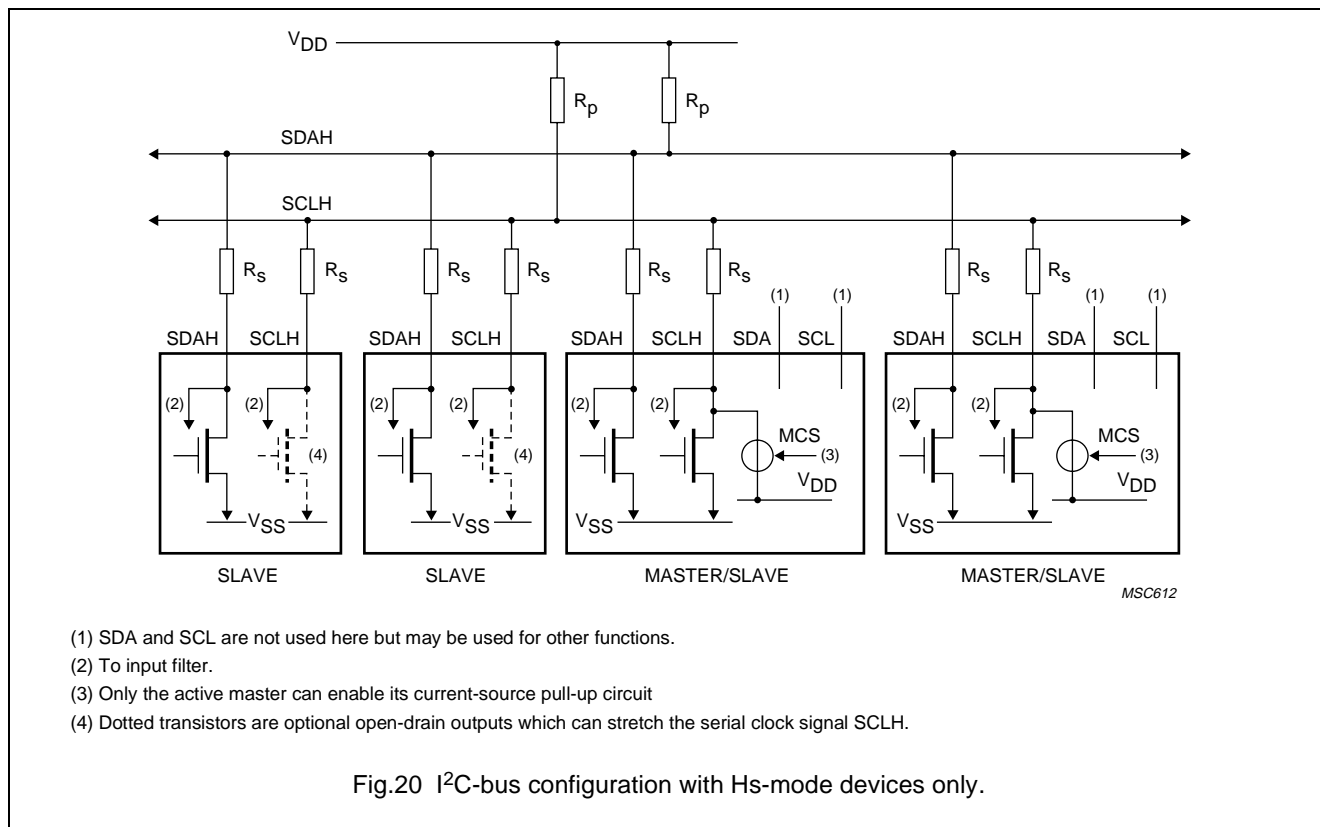

Fig.20 I²C-bus configuration with Hs-mode devices only.

13.2 Serial data transfer format in Hs-mode

Serial data transfer format in Hs-mode meets the Standard-mode I²C-bus specification. Hs-mode can only commence after the following conditions (all of which are in F/S-mode):

1. START condition (S)
2. 8-bit master code (00001XXX)
3. not-acknowledge bit (\bar{A})

Figures 21 and 22 show this in more detail. This master code has two main functions:

- It allows arbitration and synchronization between competing masters at F/S-mode speeds, resulting in one winning master.
- It indicates the beginning of an Hs-mode transfer.

Hs-mode master codes are reserved 8-bit codes, which are not used for slave addressing or other purposes. Furthermore, as each master has its own unique master code, up to eight Hs-mode masters can be present on the one I²C-bus system (although master code 0000 1000 should be reserved for test and diagnostic purposes). The

master code for an Hs-mode master device is software programmable and is chosen by the System Designer.

Arbitration and clock synchronization only take place during the transmission of the master code and not-acknowledge bit (\bar{A}), after which one winning master remains active. The master code indicates to other devices that an Hs-mode transfer is to begin and the connected devices must meet the Hs-mode specification. As no device is allowed to acknowledge the master code, the master code is followed by a not-acknowledge (\bar{A}).

After the not-acknowledge bit (\bar{A}), and the SCLH line has been pulled-up to a HIGH level, the active master switches to Hs-mode and enables (at time t_H , see Fig.22) the current-source pull-up circuit for the SCLH signal. As other devices can delay the serial transfer before t_H by stretching the LOW period of the SCLH signal, the active master will enable its current-source pull-up circuit when all devices have released the SCLH line and the SCLH signal has reached a HIGH level, thus speeding up the last part of the rise time of the SCLH signal.

The active master then sends a repeated START condition (Sr) followed by a 7-bit slave address (or 10-bit slave

The I²C-bus specification

address, see Section 14) with a R/\bar{W} bit address, and receives an acknowledge bit (A) from the selected slave.

After a repeated START condition and after each acknowledge bit (A) or not-acknowledge bit (\bar{A}), the active master disables its current-source pull-up circuit. This enables other devices to delay the serial transfer by stretching the LOW period of the SCLH signal. The active master re-enables its current-source pull-up circuit again

when all devices have released and the SCLH signal reaches a HIGH level, and so speeds up the last part of the SCLH signal's rise time.

Data transfer continues in Hs-mode after the next repeated START (Sr), and only switches back to F/S-mode after a STOP condition (P). To reduce the overhead of the master code, it's possible that a master links a number of Hs-mode transfers, separated by repeated START conditions (Sr).

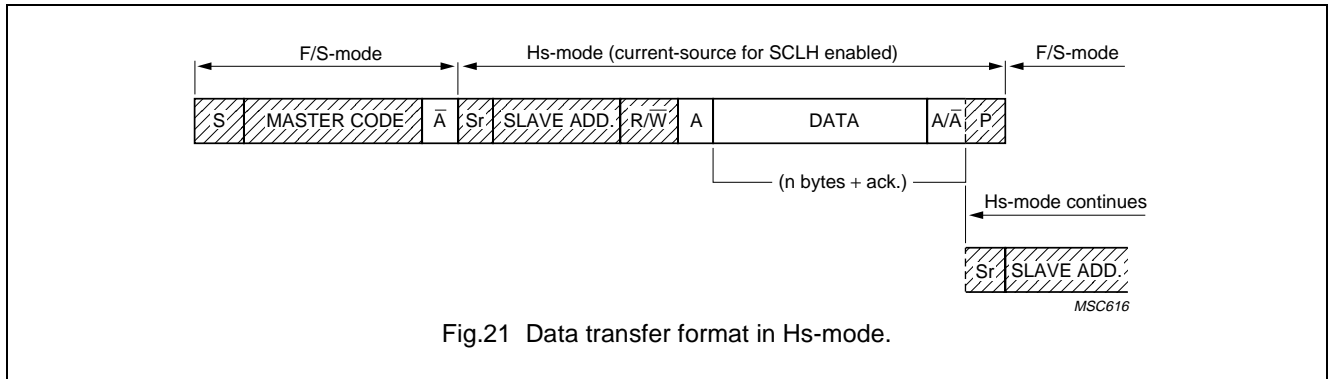

Fig.21 Data transfer format in Hs-mode.

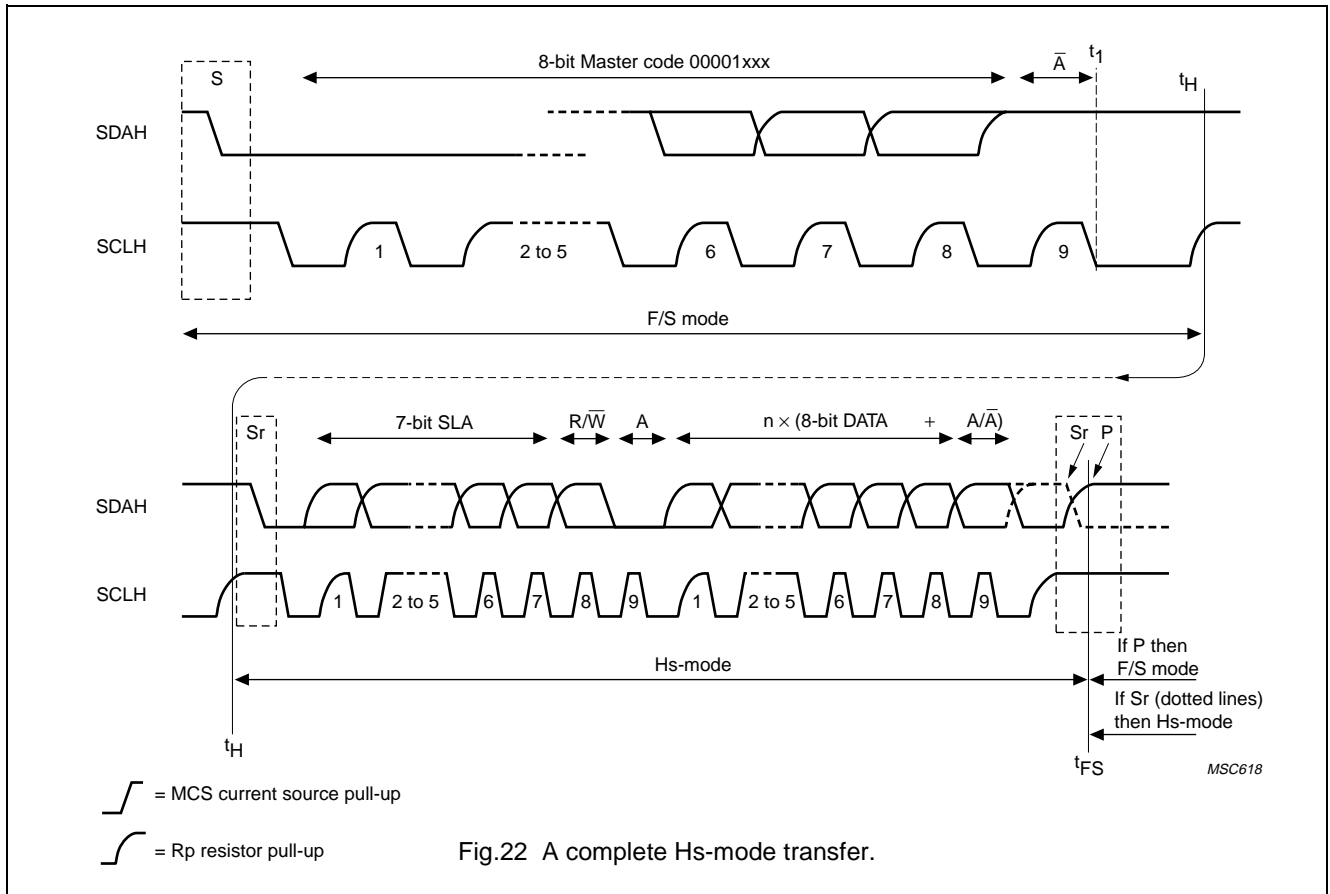

Fig.22 A complete Hs-mode transfer.

The I²C-bus specification

13.3 Switching from F/S- to Hs-mode and back

After reset and initialization, Hs-mode devices must be in Fast-mode (which is in effect F/S-mode as Fast-mode is downward compatible with Standard-mode). Each Hs-mode device can switch from Fast- to Hs-mode and back and is controlled by the serial transfer on the I²C-bus.

Before time t_1 in Fig.22, each connected device operates in Fast-mode. Between times t_1 and t_H (this time interval can be stretched by any device) each connected device must recognize the “S 00001XXX \bar{A} ” sequence and has to switch its internal circuit from the Fast-mode setting to the Hs-mode setting. Between times t_1 and t_H the connected master and slave devices perform this switching by the following actions.

The active (winning) master:

1. Adapts its SDAH and SCLH input filters according to the spike suppression requirement in Hs-mode.
2. Adapts the set-up and hold times according to the Hs-mode requirements.
3. Adapts the slope control of its SDAH and SCLH output stages according to the Hs-mode requirement.
4. Switches to the Hs-mode bit-rate, which is required after time t_H .
5. Enables the current source pull-up circuit of its SCLH output stage at time t_H .

The non-active, or losing masters:

1. Adapt their SDAH and SCLH input filters according to the spike suppression requirement in Hs-mode.
2. Wait for a STOP condition to detect when the bus is free again.

All slaves:

1. Adapt their SDAH and SCLH input filters according to the spike suppression requirement in Hs-mode.
2. Adapt the set-up and hold times according to the Hs-mode requirements. This requirement may already be fulfilled by the adaptation of the input filters.
3. Adapt the slope control of their SDAH output stages, if necessary. For slave devices, slope control is applicable for the SDAH output stage only and, depending on circuit tolerances, both the Fast- and Hs-mode requirements may be fulfilled without switching its internal circuit.

At time t_{FS} in Fig.22, each connected device must recognize the STOP condition (P) and switch its internal circuit from the Hs-mode setting back to the Fast-mode setting as present before time t_1 . This must be completed within the minimum bus free time as specified in Table 5 according to the Fast-mode specification.

The I²C-bus specification

13.4 Hs-mode devices at lower speed modes

Hs-mode devices are fully downwards compatible, and can be connected to an F/S-mode I²C-bus system (see Fig.23). As no master code will be transmitted in such a configuration, all Hs-mode master devices stay in

F/S-mode and communicate at F/S-mode speeds with their current-source disabled. The SDAH and SCLH pins are used to connect to the F/S-mode bus system, allowing the SDA and SCL pins (if present) on the Hs-mode master device to be used for other functions.

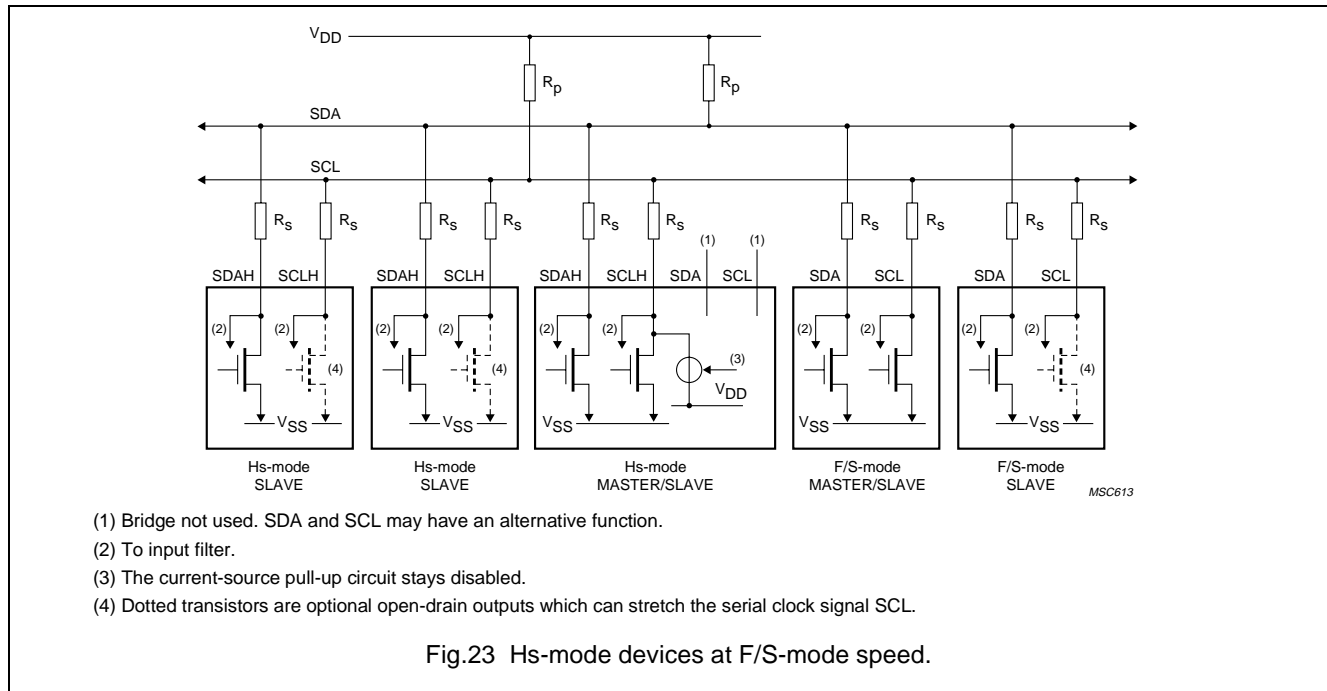

Fig.23 Hs-mode devices at F/S-mode speed.

13.5 Mixed speed modes on one serial bus system

If a system has a combination of Hs-, Fast- and/or Standard-mode devices, it's possible, by using an interconnection bridge, to have different bit rates between different devices (see Figs 24 and 25).

One bridge is required to connect/disconnect an Hs-mode section to/from an F/S-mode section at the appropriate time. This bridge includes a level shift function that allows devices with different supply voltages to be connected. For example F/S-mode devices with a V_{DD2} of 5 V can be connected to Hs-mode devices with a V_{DD1} of 3 V or less (i.e. where $V_{DD2} \geq V_{DD1}$), provided SDA and SCL pins are 5 V tolerant. This bridge is incorporated in Hs-mode master devices and is completely controlled by the serial signals SDAH, SCLH, SDA and SCL. Such a bridge can be implemented in any IC as an autonomous circuit.

TR1, TR2 and TR3 are N-channel transistors. TR1 and TR2 have a transfer gate function, and TR3 is an open-drain pull-down stage. If TR1 or TR2 are switched on they transfer a LOW level in both directions, otherwise when both the drain and source rise to a HIGH level there will be

a high impedance between the drain and source of each switched on transistor. In the latter case, the transistors will act as a level shifter as SDAH and SCLH will be pulled-up to V_{DD1} and SDA and SCL will be pulled-up to V_{DD2}

During F/S-mode speed, a bridge on one of the Hs-mode masters connects the SDAH and SCLH lines to the corresponding SDA and SCL lines thus permitting Hs-mode devices to communicate with F/S-mode devices at slower speeds. Arbitration and synchronization is possible during the total F/S-mode transfer between all connected devices as described in Section 8. During Hs-mode transfer, however, the bridge opens to separate the two bus sections and allows Hs-mode devices to communicate with each other at 3.4 Mbit/s. Arbitration between Hs-mode devices and F/S-mode devices is only performed during the master code (00001XXX), and normally won by one Hs-mode master as no slave address has four leading zeros. Other masters can win the arbitration only if they send a reserved 8-bit code (00000XXX). In such cases, the bridge remains closed and the transfer proceeds in F/S-mode. Table 3 gives the possible communication speeds in such a system.

The I²C-bus specification

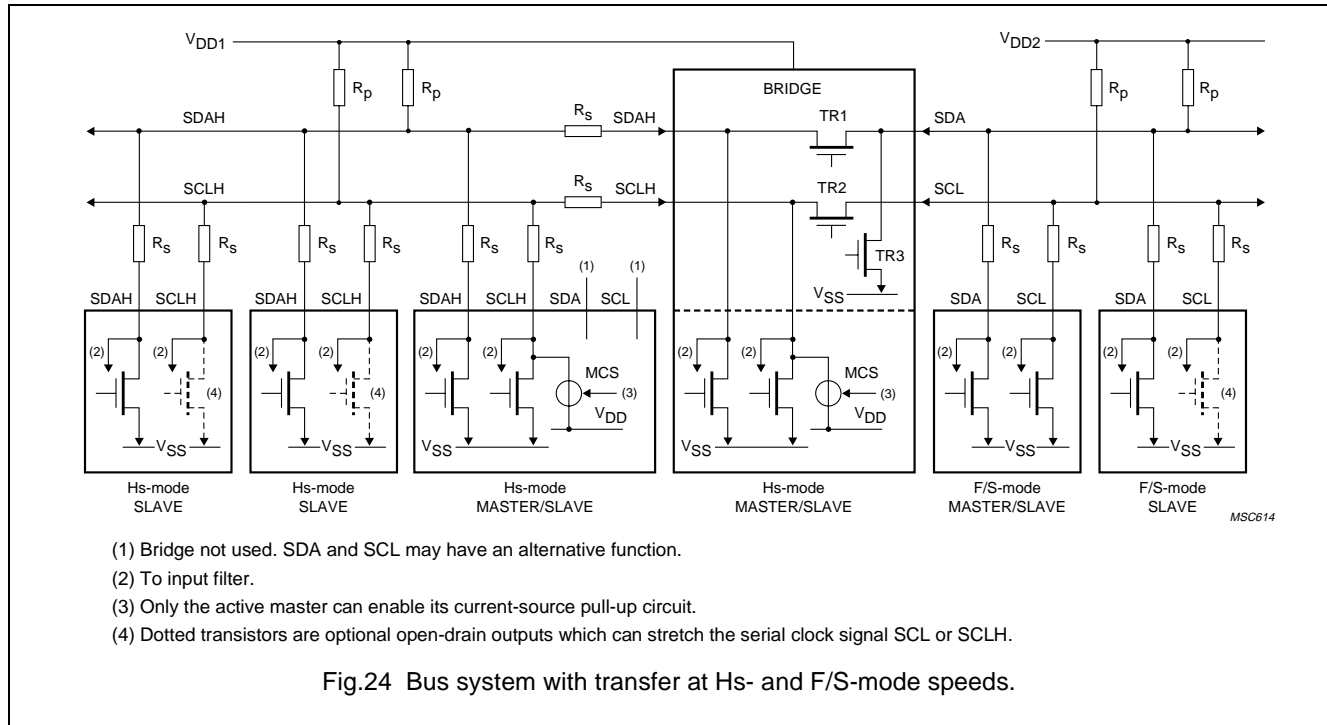

Fig.24 Bus system with transfer at Hs- and F/S-mode speeds.

Table 3 Communication bit-rates in a mixed speed bus system

TRANSFER BETWEEN	SERIAL BUS SYSTEM CONFIGURATION			
	Hs + FAST + STANDARD	Hs + FAST	Hs + STANDARD	FAST + STANDARD
Hs ↔ Hs	0 to 3.4 Mbit/s	0 to 3.4 Mbit/s	0 to 3.4 Mbit/s	–
Hs ↔ Fast	0 to 100 kbit/s	0 to 400 kbit/s	–	–
Hs ↔ Standard	0 to 100 kbit/s	–	0 to 100 kbit/s	–
Fast ↔ Standard	0 to 100 kbit/s	–	–	0 to 100 kbit/s
Fast ↔ Fast	0 to 100 kbit/s	0 to 400 kbit/s	–	0 to 100 kbit/s
Standard ↔ Standard	0 to 100 kbit/s	–	0 to 100 kbit/s	0 to 100 kbit/s

13.5.1 F/S-MODE TRANSFER IN A MIXED-SPEED BUS SYSTEM

The bridge shown in Fig.24 interconnects corresponding serial bus lines, forming one serial bus system. As no master code (00001XXX) is transmitted, the current-source pull-up circuits stay disabled and all output stages are open-drain. All devices, including Hs-mode devices, communicate with each other according the protocol, format and speed of the F/S-mode I²C-bus specification.

13.5.2 HS-MODE TRANSFER IN A MIXED-SPEED BUS SYSTEM

Figure 25 shows the timing diagram of a complete Hs-mode transfer, which is invoked by a START condition, a master code, and a not-acknowledge \bar{A} (at F/S-mode speed). Although this timing diagram is split in two parts, it should be viewed as one timing diagram were time point t_H is a common point for both parts.

The I²C-bus specification

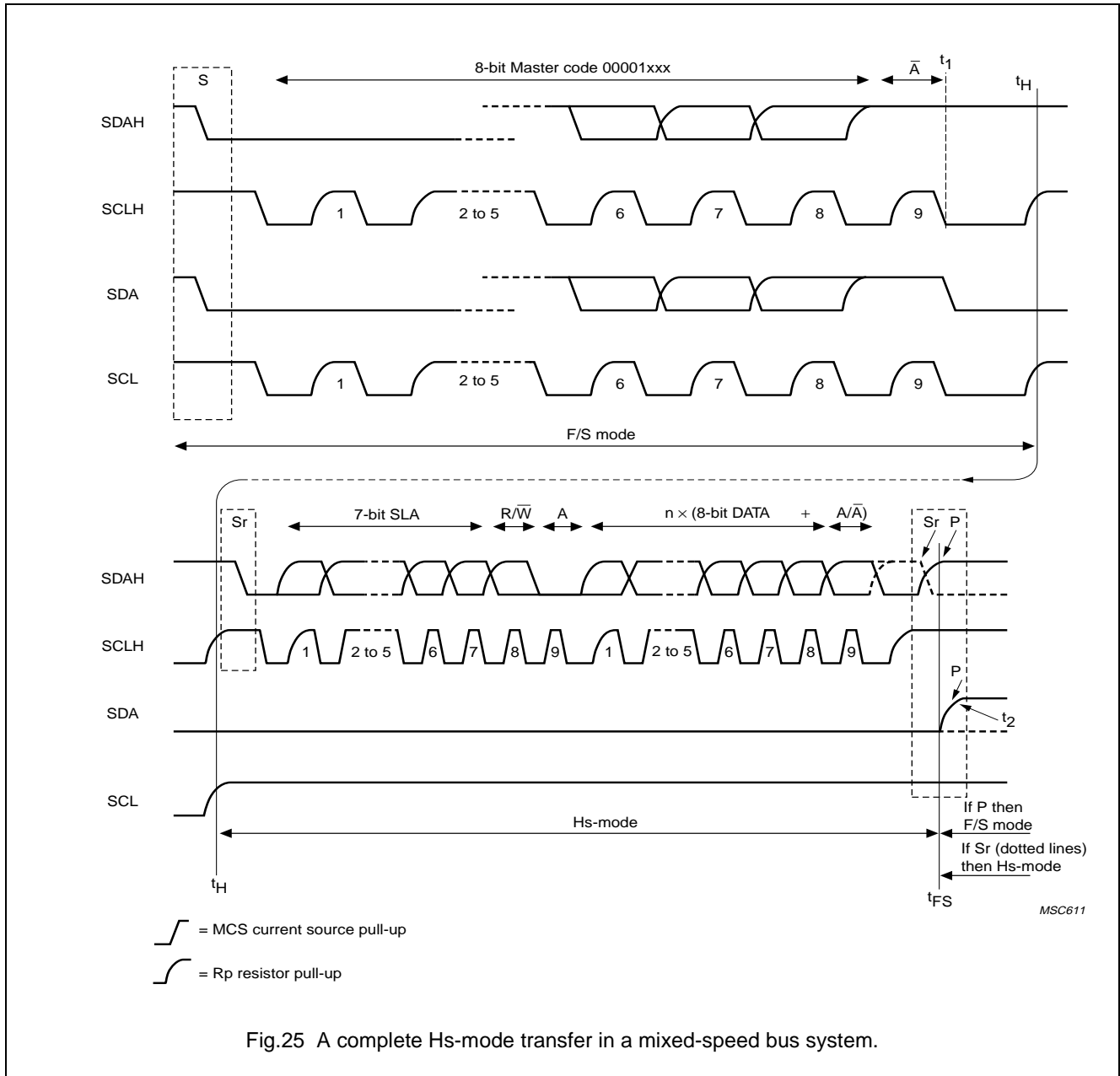

Fig.25 A complete Hs-mode transfer in a mixed-speed bus system.

The master code is recognized by the bridge in the active or non-active master (see Fig.24). The bridge performs the following actions:

1. Between t_1 and t_H (see Fig.25), transistor TR1 opens to separate the SDAH and SDA lines, after which transistor TR3 closes to pull-down the SDA line to V_{SS} .

2. When both SCLH and SCL become HIGH (t_H in Fig.25), transistor TR2 opens to separate the SCLH and SCL lines. TR2 must be opened before SCLH goes LOW after Sr.

Hs-mode transfer starts after t_H with a repeated START condition (Sr). During Hs-mode transfer, the SCL line stays at a HIGH and the SDA line at a LOW steady-state level, and so is prepared for the transfer of a STOP condition (P).

The I²C-bus specification

After each acknowledge (A) or not-acknowledge bit (\bar{A}) the active master disables its current-source pull-up circuit. This enables other devices to delay the serial transfer by stretching the LOW period of the SCLH signal. The active master re-enables its current-source pull-up circuit again when all devices are released and the SCLH signal reaches a HIGH level, and so speeds up the last part of the SCLH signal's rise time. In irregular situations, F/S-mode devices can close the bridge (TR1 and TR2 closed, TR3 open) at any time by pulling down the SCL line for at least 1 μ s, e.g. to recover from a bus hang-up.

Hs-mode finishes with a STOP condition and brings the bus system back into the F/S-mode. The active master disables its current-source MCS when the STOP condition (P) at SDAH is detected (t_{FS} in Fig.25). The bridge also recognizes this STOP condition and takes the following actions:

1. Transistor TR2 closes after t_{FS} to connect SCLH with SCL; both of which are HIGH at this time. Transistor TR3 opens after t_{FS} , which releases the SDA line and allows it to be pulled HIGH by the pull-up resistor R_p . This is the STOP condition for the F/S-mode devices. TR3 must open fast enough to ensure the bus free time between the STOP condition and the earliest next START condition is according to the Fast-mode specification (see t_{BUF} in Table 5).
2. When SDA reaches a HIGH (t_2 in Fig.25) transistor TR1 closes to connect SDAH with SDA. (Note: interconnections are made when all lines are HIGH, thus preventing spikes on the bus lines). TR1 and TR2 must be closed within the minimum bus free time according to the Fast-mode specification (see t_{BUF} in Table 5).

13.5.3 TIMING REQUIREMENTS FOR THE BRIDGE IN A MIXED-SPEED BUS SYSTEM

It can be seen from Fig.25 that the actions of the bridge at t_1 , t_H and t_{FS} must be so fast that it does not affect the SDAH and SCLH lines. Furthermore the bridge must meet the related timing requirements of the Fast-mode specification for the SDA and SCL lines.

14 10-BIT ADDRESSING

This section describes 10-bit addressing and can be disregarded if only 7-bit addressing is used.

10-bit addressing is compatible with, and can be combined with, 7-bit addressing. Using 10 bits for addressing exploits the reserved combination 1111XXX for the first

seven bits of the first byte following a START (S) or repeated START (Sr) condition as explained in Section 10.1. The 10-bit addressing does not affect the existing 7-bit addressing. Devices with 7-bit and 10-bit addresses can be connected to the same I²C-bus, and both 7-bit and 10-bit addressing can be used in F/S-mode and Hs-mode systems.

Although there are eight possible combinations of the reserved address bits 1111XXX, only the four combinations 11110XX are used for 10-bit addressing. The remaining four combinations 11111XX are reserved for future I²C-bus enhancements.

14.1 Definition of bits in the first two bytes

The 10-bit slave address is formed from the first two bytes following a START condition (S) or a repeated START condition (Sr).

The first seven bits of the first byte are the combination 11110XX of which the last two bits (XX) are the two most-significant bits (MSBs) of the 10-bit address; the eighth bit of the first byte is the R/\bar{W} bit that determines the direction of the message. A 'zero' in the least significant position of the first byte means that the master will write information to a selected slave. A 'one' in this position means that the master will read information from the slave.

If the R/\bar{W} bit is 'zero', then the second byte contains the remaining 8 bits (XXXXXXXX) of the 10-bit address. If the R/\bar{W} bit is 'one', then the next byte contains data transmitted from a slave to a master.

14.2 Formats with 10-bit addresses

Various combinations of read/write formats are possible within a transfer that includes 10-bit addressing. Possible data transfer formats are:

- Master-transmitter transmits to slave-receiver with a 10-bit slave address.

The transfer direction is not changed (see Fig.26). When a 10-bit address follows a START condition, each slave compares the first seven bits of the first byte of the slave address (11110XX) with its own address and tests if the eighth bit (R/\bar{W} direction bit) is 0. It is possible that more than one device will find a match and generate an acknowledge (A1). All slaves that found a match will compare the eight bits of the second byte of the slave address (XXXXXXXX) with their own addresses, but only one slave will find a match and generate an acknowledge (A2). The matching slave will remain addressed by the master until it receives a STOP

The I²C-bus specification

condition (P) or a repeated START condition (Sr) followed by a different slave address.

- Master-receiver reads slave- transmitter with a 10-bit slave address.
 The transfer direction is changed after the second $\overline{R/\overline{W}}$ bit (Fig.27). Up to and including acknowledge bit A2, the procedure is the same as that described for a master-transmitter addressing a slave-receiver. After the repeated START condition (Sr), a matching slave remembers that it was addressed before. This slave then checks if the first seven bits of the first byte of the slave address following Sr are the same as they were after the START condition (S), and tests if the eighth ($\overline{R/\overline{W}}$) bit is 1. If there is a match, the slave considers that it has been addressed as a transmitter and generates acknowledge A3. The slave-transmitter remains addressed until it receives a STOP condition (P) or until it receives another repeated START condition (Sr) followed by a different slave address. After a repeated START condition (Sr), all the other slave devices will also compare the first seven bits of the first byte of the slave address (11110XX) with their own addresses and test the eighth ($\overline{R/\overline{W}}$) bit. However, none of them will be addressed because $\overline{R/\overline{W}} = 1$ (for 10-bit devices), or the 11110XX slave address (for 7-bit devices) does not match.
- Combined format. A master transmits data to a slave and then reads data from the same slave (Fig.28). The same master occupies the bus all the time. The transfer direction is changed after the second $\overline{R/\overline{W}}$ bit.

- Combined format. A master transmits data to one slave and then transmits data to another slave (Fig.29). The same master occupies the bus all the time.
- Combined format. 10-bit and 7-bit addressing combined in one serial transfer (Fig.30). After each START condition (S), or each repeated START condition (Sr), a 10-bit or 7-bit slave address can be transmitted. Figure 30 shows how a master transmits data to a slave with a 7-bit address and then transmits data to a second slave with a 10-bit address. The same master occupies the bus all the time.

NOTES:

- Combined formats can be used, for example, to control a serial memory. During the first data byte, the internal memory location has to be written. After the START condition and slave address is repeated, data can be transferred.
- All decisions on auto-increment or decrement of previously accessed memory locations etc. are taken by the designer of the device.
- Each byte is followed by an acknowledgment bit as indicated by the A or blocks in the sequence.
- I²C-bus compatible devices must reset their bus logic on receipt of a START or repeated START condition such that they all anticipate the sending of a slave address.

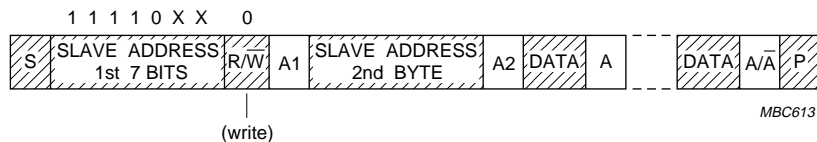

Fig.26 A master-transmitter addresses a slave-receiver with a 10-bit address.

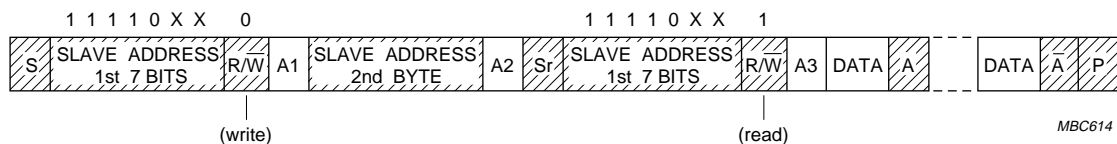

Fig.27 A master-receiver addresses a slave-transmitter with a 10-bit address.

The I²C-bus specification

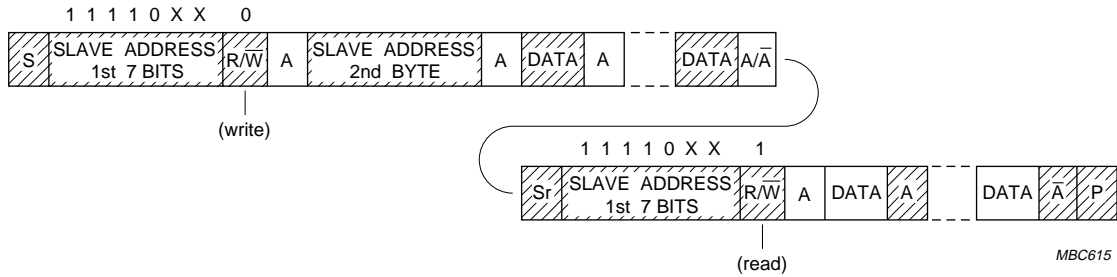

Fig.28 Combined format. A master addresses a slave with a 10-bit address, then transmits data to this slave and reads data from this slave.

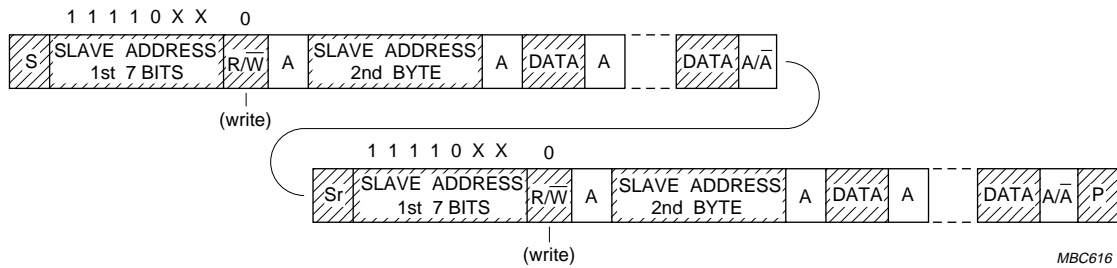

Fig.29 Combined format. A master transmits data to two slaves, both with 10-bit addresses.

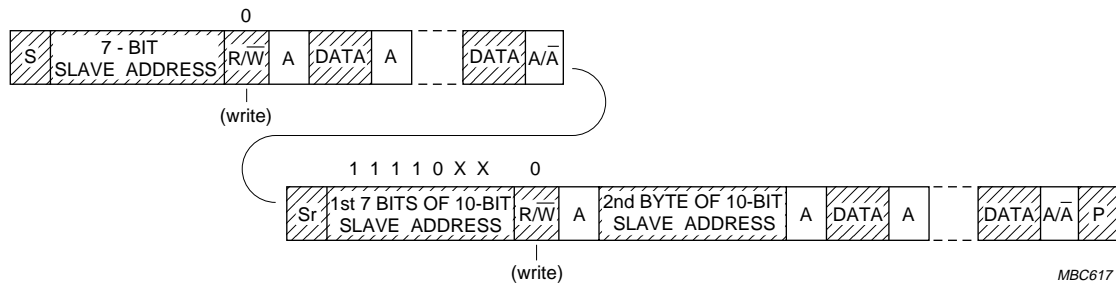

Fig.30 Combined format. A master transmits data to two slaves, one with a 7-bit address, and one with a 10-bit address.

The I²C-bus specification

14.3 General call address and start byte with 10-bit addressing

The 10-bit addressing procedure for the I²C-bus is such that the first two bytes after the START condition (S) usually determine which slave will be selected by the master. The exception is the “general call” address 00000000 (H'00'). Slave devices with 10-bit addressing will react to a “general call” in the same way as slave devices with 7-bit addressing (see Section 10.1.1).

Hardware masters can transmit their 10-bit address after a ‘general call’. In this case, the ‘general call’ address byte is followed by two successive bytes containing the 10-bit address of the master-transmitter. The format is as shown in Fig.10 where the first DATA byte contains the eight least-significant bits of the master address.

The START byte 00000001 (H'01') can precede the 10-bit addressing in the same way as for 7-bit addressing (see Section 10.1.2).

15 ELECTRICAL SPECIFICATIONS AND TIMING FOR I/O STAGES AND BUS LINES

15.1 Standard- and Fast-mode devices

The I/O levels, I/O current, spike suppression, output slope control and pin capacitance for F/S-mode I²C-bus devices are given in Table 4. The I²C-bus timing characteristics, bus-line capacitance and noise margin are given in Table 5. Figure 31 shows the timing definitions for the I²C-bus.

The minimum HIGH and LOW periods of the SCL clock specified in Table 5 determine the maximum bit transfer rates of 100 kbit/s for Standard-mode devices and 400 kbit/s for Fast-mode devices. Standard-mode and Fast-mode I²C-bus devices must be able to follow transfers at their own maximum bit rates, either by being able to transmit or receive at that speed or by applying the clock synchronization procedure described in Section 8 which will force the master into a wait state and stretch the LOW period of the SCL signal. Of course, in the latter case the bit transfer rate is reduced.

The I²C-bus specification

Table 4 Characteristics of the SDA and SCL I/O stages for F/S-mode I²C-bus devices

PARAMETER	SYMBOL	STANDARD-MODE		FAST-MODE		UNIT
		MIN.	MAX.	MIN.	MAX.	
LOW level input voltage: fixed input levels V _{DD} -related input levels	V _{IL}	-0.5	1.5	n/a	n/a	V
		-0.5	0.3V _{DD}	-0.5	0.3V _{DD} ⁽¹⁾	V
HIGH level input voltage: fixed input levels V _{DD} -related input levels	V _{IH}	3.0	⁽²⁾	n/a	n/a	V
		0.7V _{DD}	⁽²⁾	0.7V _{DD} ⁽¹⁾	⁽²⁾	V
Hysteresis of Schmitt trigger inputs: V _{DD} > 2 V V _{DD} < 2 V	V _{hys}	n/a	n/a	0.05V _{DD}	–	V
		n/a	n/a	0.1V _{DD}	–	V
LOW level output voltage (open drain or open collector) at 3 mA sink current: V _{DD} > 2 V V _{DD} < 2 V	V _{OL1}	0	0.4	0	0.4	V
	V _{OL3}	n/a	n/a	0	0.2V _{DD}	V
Output fall time from V _{IHmin} to V _{ILmax} with a bus capacitance from 10 pF to 400 pF	t _{of}	–	250 ⁽⁴⁾	20 + 0.1C _b ⁽³⁾	250 ⁽⁴⁾	ns
Pulse width of spikes which must be suppressed by the input filter	t _{SP}	n/a	n/a	0	50	ns
Input current each I/O pin with an input voltage between 0.1V _{DD} and 0.9V _{DDmax}	I _i	-10	10	-10 ⁽⁵⁾	10 ⁽⁵⁾	μA
Capacitance for each I/O pin	C _i	–	10	–	10	pF

Notes

1. Devices that use non-standard supply voltages which do not conform to the intended I²C-bus system levels must relate their input levels to the V_{DD} voltage to which the pull-up resistors R_p are connected.
2. Maximum V_{IH} = V_{DDmax} + 0.5 V.
3. C_b = capacitance of one bus line in pF.
4. The maximum t_f for the SDA and SCL bus lines quoted in Table 5 (300 ns) is longer than the specified maximum t_{of} for the output stages (250 ns). This allows series protection resistors (R_s) to be connected between the SDA/SCL pins and the SDA/SCL bus lines as shown in Fig.36 without exceeding the maximum specified t_f.
5. I/O pins of Fast-mode devices must not obstruct the SDA and SCL lines if V_{DD} is switched off.

n/a = not applicable

The I²C-bus specification

Table 5 Characteristics of the SDA and SCL bus lines for F/S-mode I²C-bus devices⁽¹⁾

PARAMETER	SYMBOL	STANDARD-MODE		FAST-MODE		UNIT
		MIN.	MAX.	MIN.	MAX.	
SCL clock frequency	f _{SCL}	0	100	0	400	kHz
Hold time (repeated) START condition. After this period, the first clock pulse is generated	t _{HD;STA}	4.0	–	0.6	–	μs
LOW period of the SCL clock	t _{LOW}	4.7	–	1.3	–	μs
HIGH period of the SCL clock	t _{HIGH}	4.0	–	0.6	–	μs
Set-up time for a repeated START condition	t _{SU;STA}	4.7	–	0.6	–	μs
Data hold time: for CBUS compatible masters (see NOTE, Section 10.1.3) for I ² C-bus devices	t _{HD;DAT}	5.0 0 ⁽²⁾	– 3.45 ⁽³⁾	– 0 ⁽²⁾	– 0.9 ⁽³⁾	μs μs
Data set-up time	t _{SU;DAT}	250	–	100 ⁽⁴⁾	–	ns
Rise time of both SDA and SCL signals	t _r	–	1000	20 + 0.1C _b ⁽⁵⁾	300	ns
Fall time of both SDA and SCL signals	t _f	–	300	20 + 0.1C _b ⁽⁵⁾	300	ns
Set-up time for STOP condition	t _{SU;STO}	4.0	–	0.6	–	μs
Bus free time between a STOP and START condition	t _{BUF}	4.7	–	1.3	–	μs
Capacitive load for each bus line	C _b	–	400	–	400	pF
Noise margin at the LOW level for each connected device (including hysteresis)	V _{nL}	0.1V _{DD}	–	0.1V _{DD}	–	V
Noise margin at the HIGH level for each connected device (including hysteresis)	V _{nH}	0.2V _{DD}	–	0.2V _{DD}	–	V

Notes

- All values referred to V_{IHmin} and V_{ILmax} levels (see Table 4).
- A device must internally provide a hold time of at least 300 ns for the SDA signal (referred to the V_{IHmin} of the SCL signal) to bridge the undefined region of the falling edge of SCL.
- The maximum t_{HD;DAT} has only to be met if the device does not stretch the LOW period (t_{LOW}) of the SCL signal.
- A Fast-mode I²C-bus device can be used in a Standard-mode I²C-bus system, but the requirement t_{SU;DAT} ≥ 250 ns must then be met. This will automatically be the case if the device does not stretch the LOW period of the SCL signal. If such a device does stretch the LOW period of the SCL signal, it must output the next data bit to the SDA line t_{r,max} + t_{SU;DAT} = 1000 + 250 = 1250 ns (according to the Standard-mode I²C-bus specification) before the SCL line is released.
- C_b = total capacitance of one bus line in pF. If mixed with Hs-mode devices, faster fall-times according to Table 6 are allowed.

n/a = not applicable

The I²C-bus specification

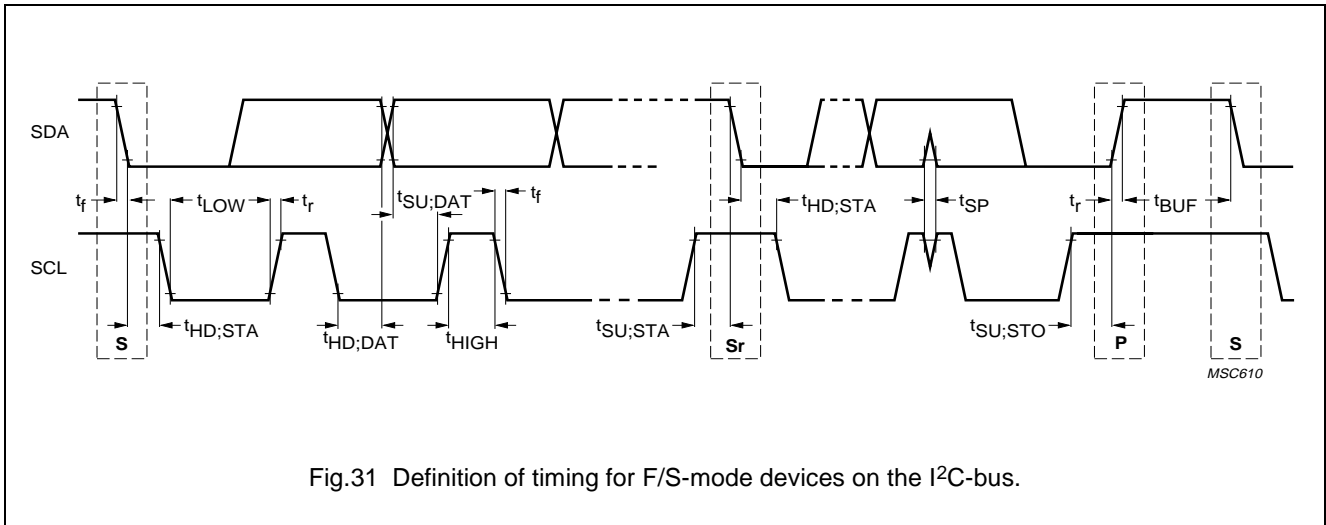

Fig.31 Definition of timing for F/S-mode devices on the I²C-bus.

The I²C-bus specification

15.2 Hs-mode devices

The I/O levels, I/O current, spike suppression, output slope control and pin capacitance for I²C-bus Hs-mode devices are given in Table 6. The noise margin for HIGH and LOW levels on the bus lines are the same as specified for F/S-mode I²C-bus devices.

Figure 32 shows all timing parameters for the Hs-mode timing. The “normal” START condition S does not exist in Hs-mode. Timing parameters for Address bits, R/W bit, Acknowledge bit and DATA bits are all the same. Only the rising edge of the first SCLH clock signal after an acknowledge bit has a larger value because the external R_p has to pull-up SCLH without the help of the internal current-source.

The Hs-mode timing parameters for the bus lines are specified in Table 7. The minimum HIGH and LOW periods and the maximum rise and fall times of the SCLH clock signal determine the highest bit rate.

With an internally generated SCLH signal with LOW and HIGH level periods of 200 ns and 100 ns respectively, an Hs-mode master can fulfil the timing requirements for the external SCLH clock pulses (taking the rise and fall times into account) for the maximum bit rate of 3.4 Mbit/s. So a basic frequency of 10 MHz, or a multiple of 10 MHz, can be used by an Hs-mode master to generate the SCLH signal. There are no limits for maximum HIGH and LOW periods of the SCLH clock, and there is no limit for a lowest bit rate.

Timing parameters are independent for capacitive load up to 100 pF for each bus line allowing the maximum possible bit rate of 3.4 Mbit/s. At a higher capacitive load on the bus lines, the bit rate decreases gradually. The timing parameters for a capacitive bus load of 400 pF are specified in Table 7, allowing a maximum bit rate of 1.7 Mbit/s. For capacitive bus loads between 100 pF and 400 pF, the timing parameters must be interpolated linearly. Rise and fall times are in accordance with the maximum propagation time of the transmission lines SDAH and SCLH to prevent reflections of the open ends.

The I²C-bus specification

Table 6 Characteristics of the SDAH, SCLH, SDA and SCL I/O stages for Hs-mode I²C-bus devices

PARAMETER	SYMBOL	Hs-MODE		UNIT
		MIN.	MAX.	
LOW level input voltage	V_{IL}	-0.5	$0.3V_{DD}^{(1)}$	V
HIGH level input voltage	V_{IH}	$0.7V_{DD}^{(1)}$	$V_{DD} + 0.5^{(2)}$	V
Hysteresis of Schmitt trigger inputs	V_{hys}	$0.1V_{DD}^{(1)}$	–	V
LOW level output voltage (open drain) at 3 mA sink current at SDAH, SDA and SCLH for: $V_{DD} > 2 V$ $V_{DD} < 2 V$	V_{OL}	0 0	0.4 $0.2V_{DD}$	V V
On resistance of the transfer gate, for both current directions at V_{OL} level between SDA and SDAH or SCL and SCLH at 3 mA	R_{onL}	–	50	Ω
On resistance of the transfer gate between SDA and SDAH or SCL and SCLH if both are at V_{DD} level	$R_{onH}^{(2)}$	50	–	k Ω
Pull-up current of the SCLH current-source. Applies for SCLH output levels between $0.3V_{DD}$ and $0.7V_{DD}$	I_{CS}	3	12	mA
Output rise time (current-source enabled) and fall time at SCLH with a capacitive load from 10 to 100 pF	t_{rCL}, t_{fCL}	10	40	ns
Output rise time (current-source enabled) and fall time at SCLH with an external pull-up current source of 3 mA and a capacitive load of 400 pF	$t_{rCL}^{(3)}, t_{fCL}^{(3)}$	20	80	ns
Output fall time at SDAH with a capacitive load from 10 to 100 pF	t_{fDA}	10	80	ns
Output fall time at SDAH with a capacitive load of 400 pF	$t_{fDA}^{(3)}$	20	160	ns
Pulse width of spikes at SDAH and SCLH that must be suppressed by the input filters	t_{SP}	0	10	ns
Input current each I/O pin with an input voltage between $0.1V_{DD}$ and $0.9V_{DD}$	$I_i^{(4)}$	–	10	μA
Capacitance for each I/O pin	C_i	–	10	pF

Notes

1. Devices that use non-standard supply voltages which do not conform to the intended I²C-bus system levels must relate their input levels to the V_{DD} voltage to which the pull-up resistors R_p are connected.
2. Devices that offer the level shift function must tolerate a maximum input voltage of 5.5 V at SDA and SCL.
3. For capacitive bus loads between 100 and 400 pF, the rise and fall time values must be linearly interpolated.
4. SDAH and SCLH I/O stages of Hs-mode slave devices must have floating outputs if their supply voltage has been switched off. Due to the current-source output circuit, which normally has a clipping diode to V_{DD} , this requirement is not mandatory for the SCLH or the SDAH I/O stage of Hs-mode master devices. This means that the supply voltage of Hs-mode master devices cannot be switched off without affecting the SDAH and SCLH lines.

The I²C-bus specification

Table 7 Characteristics of the SDAH, SCLH, SDA and SCL bus lines for Hs-mode I²C-bus devices⁽¹⁾

PARAMETER	SYMBOL	C _b = 100 pF MAX.		C _b = 400 pF ⁽²⁾		UNIT
		MIN.	MAX.	MIN.	MAX.	
SCLH clock frequency	f _{SCLH}	0	3.4	0	1.7	MHz
Set-up time (repeated) START condition	t _{SU;STA}	160	–	160	–	ns
Hold time (repeated) START condition	t _{HD;STA}	160	–	160	–	ns
LOW period of the SCLH clock	t _{LOW}	160	–	320	–	ns
HIGH period of the SCLH clock	t _{HIGH}	60	–	120	–	ns
Data set-up time	t _{SU;DAT}	10	–	10	–	ns
Data hold time	t _{HD;DAT}	0 ⁽³⁾	70	0 ⁽³⁾	150	ns
Rise time of SCLH signal	t _{rCL}	10	40	20	80	ns
Rise time of SCLH signal after a repeated START condition and after an acknowledge bit	t _{rCL1}	10	80	20	160	ns
Fall time of SCLH signal	t _{fCL}	10	40	20	80	ns
Rise time of SDAH signal	t _{rDA}	10	80	20	160	ns
Fall time of SDAH signal	t _{fDA}	10	80	20	160	ns
Set-up time for STOP condition	t _{SU;STO}	160	–	160	–	ns
Capacitive load for SDAH and SCLH lines	C _b ⁽²⁾	–	100	–	400	pF
Capacitive load for SDAH + SDA line and SCLH + SCL line	C _b	–	400	–	400	pF
Noise margin at the LOW level for each connected device (including hysteresis)	V _{nL}	0.1V _{DD}	–	0.1V _{DD}	–	V
Noise margin at the HIGH level for each connected device (including hysteresis)	V _{nH}	0.2V _{DD}	–	0.2V _{DD}	–	V

Notes

1. All values referred to V_{IHmin} and V_{ILmax} levels (see Table 6).
2. For bus line loads C_b between 100 and 400 pF the timing parameters must be linearly interpolated.
3. A device must internally provide a Data hold time to bridge the undefined part between V_{IH} and V_{IL} of the falling edge of the SCLH signal. An input circuit with a threshold as low as possible for the falling edge of the SCLH signal minimizes this hold time.

The I²C-bus specification

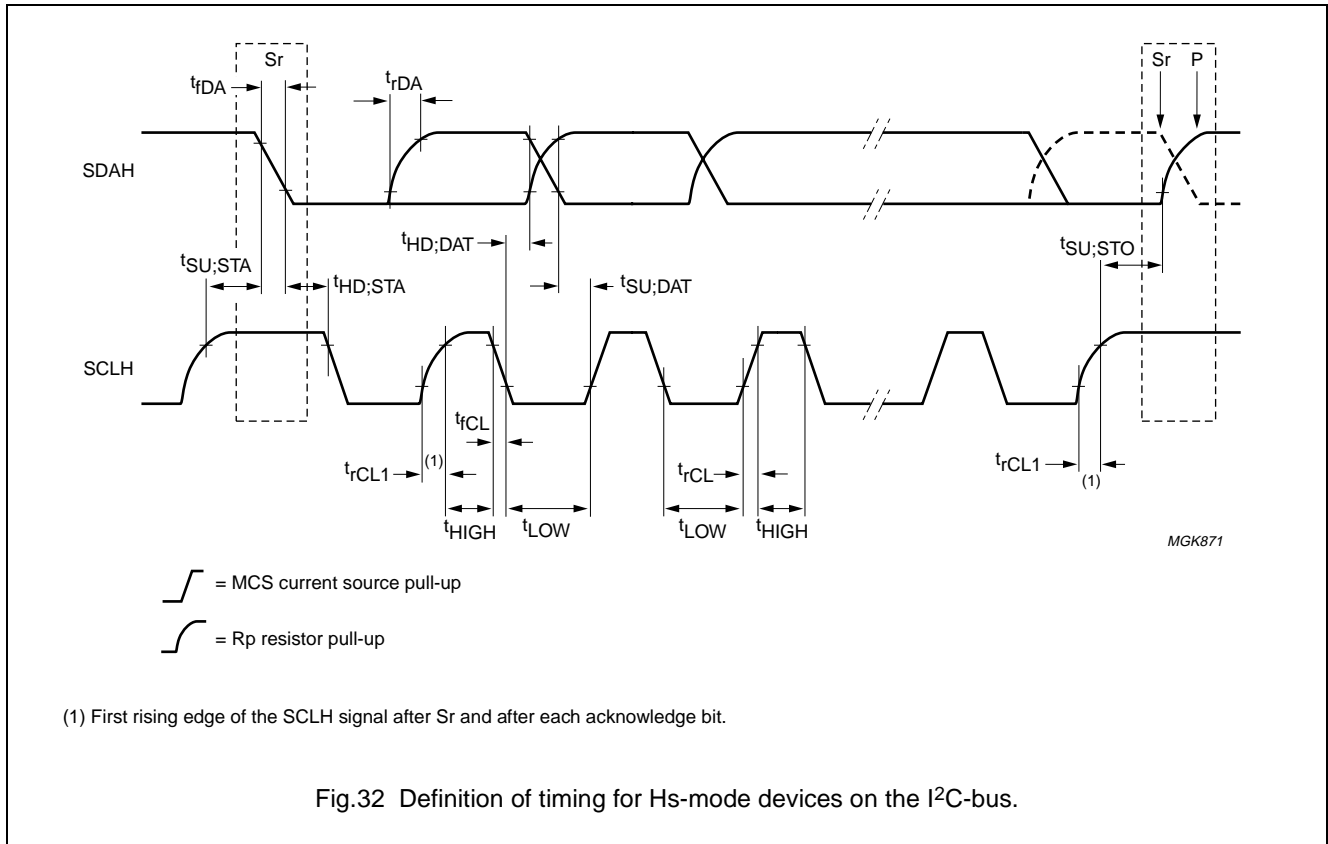

Fig.32 Definition of timing for Hs-mode devices on the I²C-bus.

16 ELECTRICAL CONNECTIONS OF I²C-BUS DEVICES TO THE BUS LINES

The electrical specifications for the I/Os of I²C-bus devices and the characteristics of the bus lines connected to them are given in Section 15.

I²C-bus devices with fixed input levels of 1.5 V and 3 V can each have their own appropriate supply voltage. Pull-up resistors must be connected to a 5 V \pm 10% supply (Fig.33). I²C-bus devices with input levels related to V_{DD} must have one common supply line to which the pull-up resistor is also connected (Fig.34).

When devices with fixed input levels are mixed with devices with input levels related to V_{DD}, the latter devices

must be connected to one common supply line of 5 V \pm 10% and must have pull-up resistors connected to their SDA and SCL pins as shown in Fig.35.

New Fast- and Hs-mode devices must have supply voltage related input levels as specified in Tables 4 and 6.

Input levels are defined in such a way that:

- The noise margin on the LOW level is 0.1V_{DD}
- The noise margin on the HIGH level is 0.2V_{DD}
- As shown in Fig.36, series resistors (R_S) of e.g. 300 Ω can be used for protection against high-voltage spikes on the SDA and SCL lines (resulting from the flash-over of a TV picture tube, for example).

The I²C-bus specification

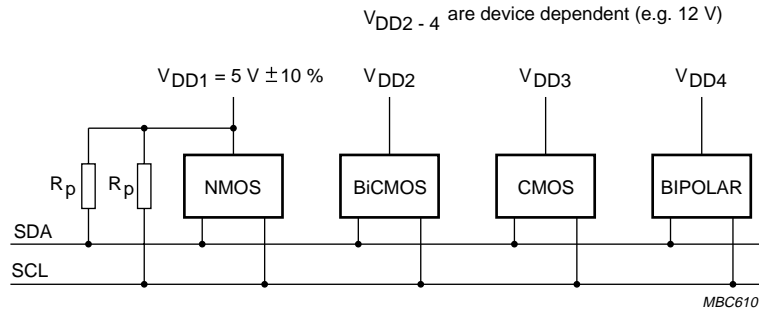

Fig.33 Fixed input level devices connected to the I²C-bus.

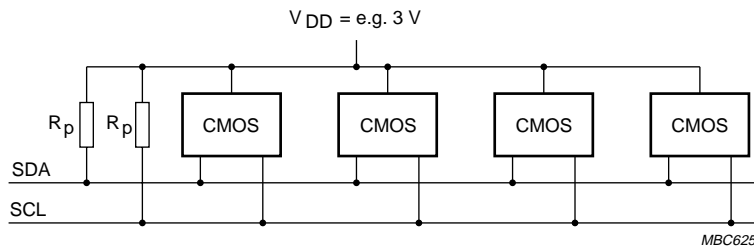

Fig.34 Devices with wide supply voltage range connected to the I²C-bus.

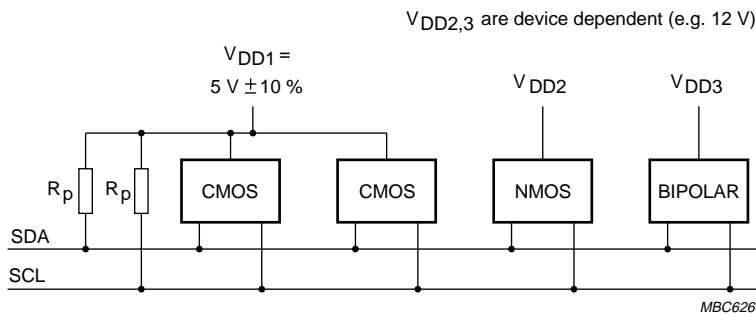

Fig.35 Devices with input levels related to V_{DD} (supply V_{DD1}) mixed with fixed input level devices (supply V_{DD2,3}) on the I²C-bus.

The I²C-bus specification

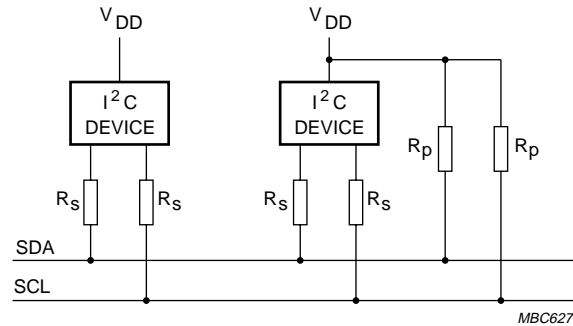

Fig.36 Series resistors (R_S) for protection against high-voltage spikes.

16.1 Maximum and minimum values of resistors R_P and R_S for Standard-mode I²C-bus devices

For Standard-mode I²C-bus systems, the values of resistors R_P and R_S in Fig.33 depend on the following parameters:

- Supply voltage
- Bus capacitance
- Number of connected devices (input current + leakage current).

The supply voltage limits the minimum value of resistor R_P due to the specified minimum sink current of 3 mA at V_{OLmax} = 0.4 V for the output stages. V_{DD} as a function of

R_{Pmin} is shown in Fig.37. The required noise margin of 0.1V_{DD} for the LOW level, limits the maximum value of R_S. R_{Smax} as a function of R_P is shown in Fig.38.

The bus capacitance is the total capacitance of wire, connections and pins. This capacitance limits the maximum value of R_P due to the specified rise time. Fig.39 shows R_{Pmax} as a function of bus capacitance.

The maximum HIGH level input current of each input/output connection has a specified maximum value of 10 μA. Due to the required noise margin of 0.2 V_{DD} for the HIGH level, this input current limits the maximum value of R_P. This limit depends on V_{DD}. The total HIGH level input current is shown as a function of R_{Pmax} in Fig.40.

The I²C-bus specification

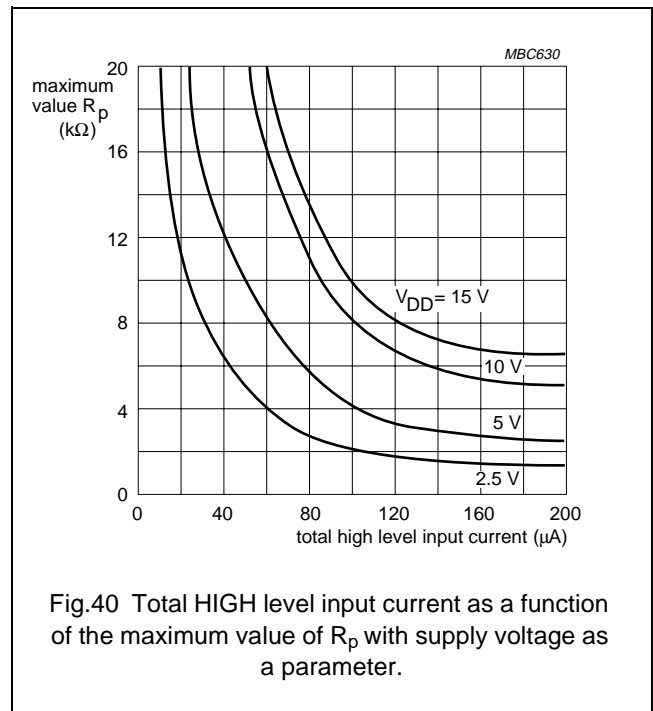
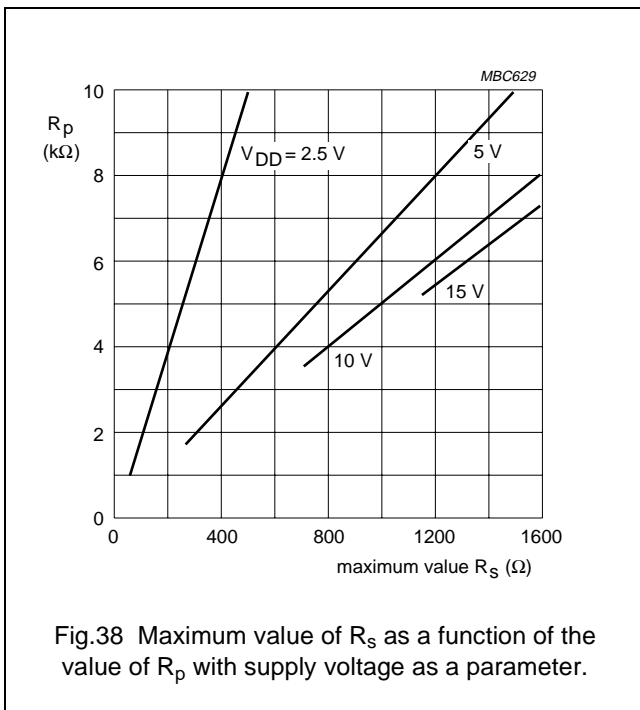
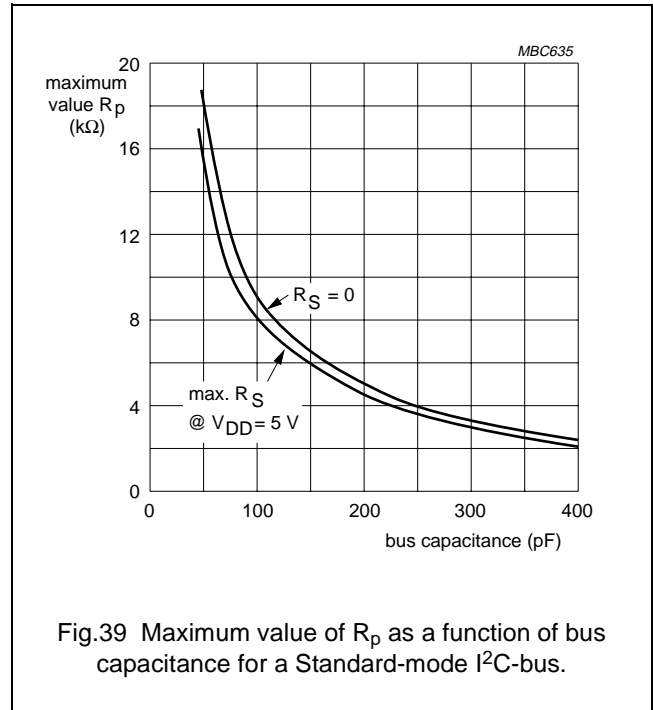
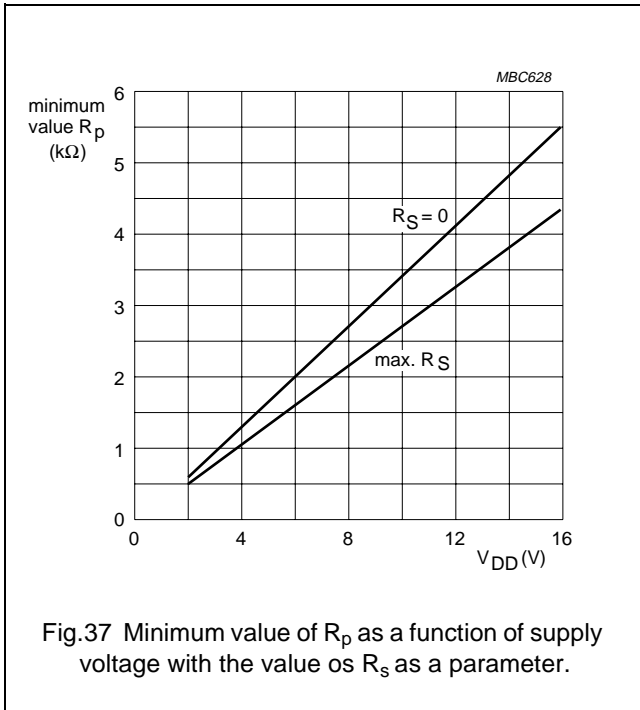

The I²C-bus specification

17 APPLICATION INFORMATION

17.1 Slope-controlled output stages of Fast-mode I²C-bus devices

The electrical specifications for the I/Os of I²C-bus devices and the characteristics of the bus lines connected to them are given in Section 15.

Figures 41 and 42 show examples of output stages with slope control in CMOS and bipolar technology. The slope of the falling edge is defined by a Miller capacitor (C1) and a resistor (R1). The typical values for C1 and R1 are indicated on the diagrams. The wide tolerance for output fall time t_{of} given in Table 4 means that the design is not critical. The fall time is only slightly influenced by the external bus load (C_b) and external pull-up resistor (R_p). However, the rise time (t_r) specified in Table 5 is mainly determined by the bus load capacitance and the value of the pull-up resistor.

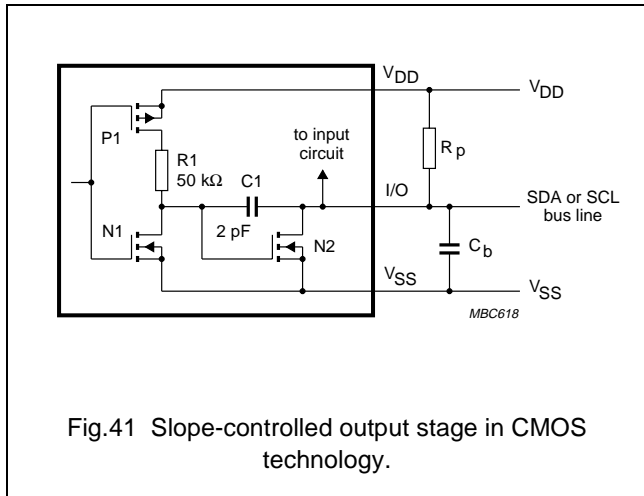

Fig.41 Slope-controlled output stage in CMOS technology.

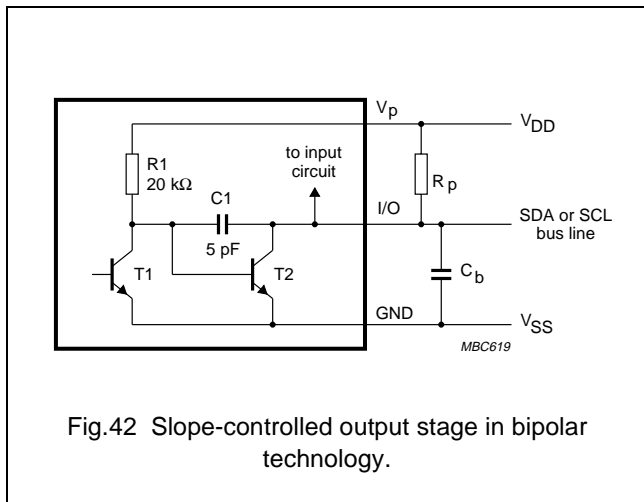

Fig.42 Slope-controlled output stage in bipolar technology.

17.2 Switched pull-up circuit for Fast-mode I²C-bus devices

The supply voltage (V_{DD}) and the maximum output LOW level determine the minimum value of pull-up resistor R_p (see Section 16.1). For example, with a supply voltage of $V_{DD} = 5 V \pm 10\%$ and $V_{OLmax} = 0.4 V$ at 3 mA, $R_{pmin} = (5.5 - 0.4)/0.003 = 1.7 k\Omega$. As shown in Fig.33, this value of R_p limits the maximum bus capacitance to about 200 pF to meet the maximum t_r requirement of 300 ns. If the bus has a higher capacitance than this, a switched pull-up circuit as shown in Fig.43 can be used.

The switched pull-up circuit in Fig.43 is for a supply voltage of $V_{DD} = 5 V \pm 10\%$ and a maximum capacitive load of 400 pF. Since it is controlled by the bus levels, it needs no additional switching control signals. During the rising/falling edges, the bilateral switch in the HCT4066 switches pull-up resistor R_{p2} on/off at bus levels between 0.8 V and 2.0 V. Combined resistors R_{p1} and R_{p2} can pull-up the bus line within the maximum specified rise time (t_r) of 300 ns.

Series resistors R_s are optional. They protect the I/O stages of the I²C-bus devices from high-voltage spikes on the bus lines, and minimize crosstalk and undershoot of the bus line signals. The maximum value of R_s is determined by the maximum permitted voltage drop across this resistor when the bus line is switched to the LOW level in order to switch off R_{p2} .

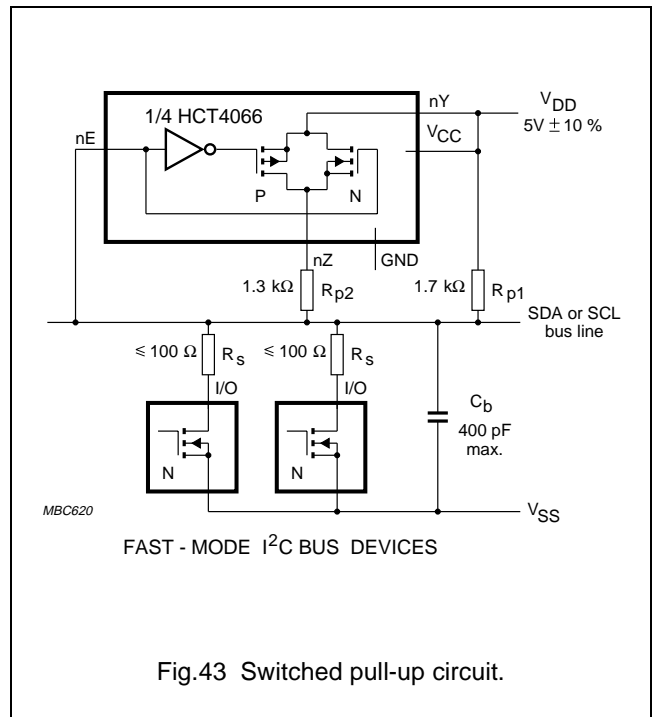

Fig.43 Switched pull-up circuit.

The I²C-bus specification

17.3 Wiring pattern of the bus lines

In general, the wiring must be so chosen that crosstalk and interference to/from the bus lines is minimized. The bus lines are most susceptible to crosstalk and interference at the HIGH level because of the relatively high impedance of the pull-up devices.

If the length of the bus lines on a PCB or ribbon cable exceeds 10 cm and includes the V_{DD} and V_{SS} lines, the wiring pattern must be:

SDA _____
 V_{DD} _____
 V_{SS} _____
 SCL _____

If only the V_{SS} line is included, the wiring pattern must be:

SDA _____
 V_{SS} _____
 SCL _____

These wiring patterns also result in identical capacitive loads for the SDA and SCL lines. The V_{SS} and V_{DD} lines can be omitted if a PCB with a V_{SS} and/or V_{DD} layer is used.

If the bus lines are twisted-pairs, each bus line must be twisted with a V_{SS} return. Alternatively, the SCL line can be twisted with a V_{SS} return, and the SDA line twisted with a V_{DD} return. In the latter case, capacitors must be used to decouple the V_{DD} line to the V_{SS} line at both ends of the twisted pairs.

If the bus lines are shielded (shield connected to V_{SS}), interference will be minimized. However, the shielded cable must have low capacitive coupling between the SDA and SCL lines to minimize crosstalk.

17.4 Maximum and minimum values of resistors R_p and R_s for Fast-mode I²C-bus devices

The maximum and minimum values for resistors R_p and R_s connected to a Fast-mode I²C-bus can be determined from Figs 37, 38 and 40 in Section 16.1. Because a Fast-mode I²C-bus has faster rise times (t_r) the maximum value of R_p as a function of bus capacitance is less than that shown in Fig.39. The replacement graph for Fig.39 showing the maximum value of R_p as a function of bus capacitance (C_b) for a Fast-mode I²C-bus is given in Fig.44.

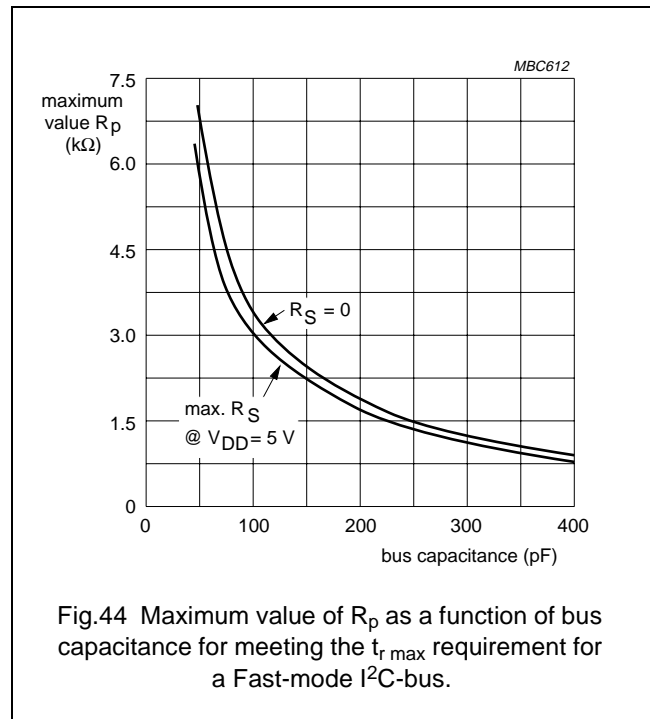

Fig.44 Maximum value of R_p as a function of bus capacitance for meeting the t_{r max} requirement for a Fast-mode I²C-bus.

17.5 Maximum and minimum values of resistors R_p and R_s for Hs-mode I²C-bus devices

The maximum and minimum values for resistors R_p and R_s connected to an Hs-mode I²C-bus can be calculated from the data in Tables 6 and 7. Many combinations of these values are possible, owing to different rise and fall times, bus line loads, supply voltages, mixed speed systems and level shifting. Because of this, no further graphs are included in this specification.

18 BI-DIRECTIONAL LEVEL SHIFTER FOR F/S-MODE I²C-BUS SYSTEMS

Present technology processes for integrated circuits with clearances of 0.5 μm and less limit the maximum supply voltage and consequently the logic levels for the digital I/O signals. To interface these lower voltage circuits with existing 5 V devices, a level shifter is needed. For bi-directional bus systems like the I²C-bus, such a level shifter must also be bi-directional, without the need of a direction control signal⁽¹⁾. The simplest way to solve this problem is by connecting a discrete MOS-FET to each bus line.

(1) US 5,689,196 granted; corresponding patent applications pending.

The I²C-bus specification

In spite of its surprising simplicity, such a solution not only fulfils the requirement of bi-directional level shifting without a direction control signal, it also:

- isolates a powered-down bus section from the rest of the bus system
- protects the “lower voltage” side against high voltage spikes from the “higher-voltage” side.

The bi-directional level shifter can be used for both Standard-mode (up to 100 kbit/s) or in Fast-mode (up to 400 kbit/s) I²C-bus systems. It is not intended for Hs-mode systems, which may have a bridge with a level shifting possibility (see Section 13.5)

18.1 Connecting devices with different logic levels

Section 16 described how different voltage devices could be connected to the same bus by using pull-up resistors to the supply voltage line. Although this is the simplest solution, the lower voltage devices must be 5 V tolerant, which can make them more expensive to manufacture. By using a bi-directional level shifter, however, it’s possible to

interconnect two sections of an I²C-bus system, with each section having a different supply voltage and different logic levels. Such a configuration is shown in Fig.45. The left “low-voltage” section has pull-up resistors and devices connected to a 3.3 V supply voltage, the right “high-voltage” section has pull-up resistors and devices connected to a 5 V supply voltage. The devices of each section have I/Os with supply voltage related logic input levels and an open drain output configuration.

The level shifter for each bus line is identical and consists of one discrete N-channel enhancement MOS-FET; TR1 for the serial data line SDA and TR2 for the serial clock line SCL. The gates (g) have to be connected to the lowest supply voltage V_{DD1} , the sources (s) to the bus lines of the “lower-voltage” section, and the drains (d) to the bus lines of the “higher-voltage” section. Many MOS-FETs have the substrate internally connected with its source, if this is not the case, an external connection should be made. Each MOS-FET has an integral diode (n-p junction) between the drain and substrate.

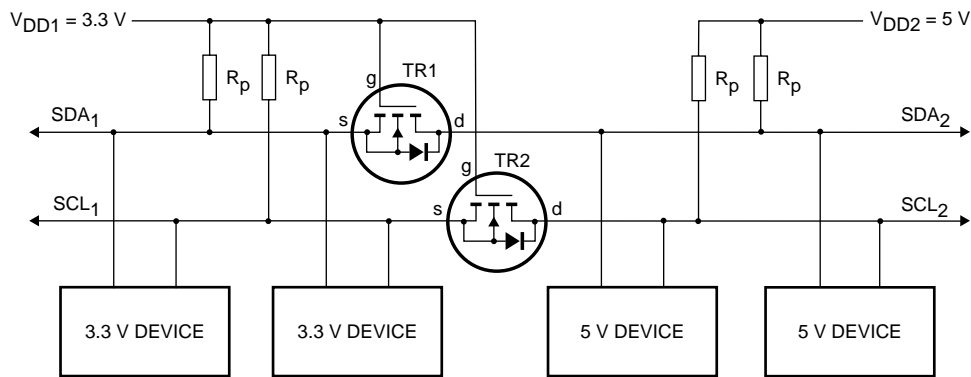

MGK879

Fig.45 Bi-directional level shifter circuit connecting two different voltage sections in an I²C-bus system.

The I²C-bus specification

18.1.1 OPERATION OF THE LEVEL SHIFTER

The following three states should be considered during the operation of the level shifter:

1. No device is pulling down the bus line.
The bus line of the “lower-voltage” section is pulled up by its pull-up resistors R_p to 3.3 V. The gate and the source of the MOS-FET are both at 3.3 V, so its V_{GS} is below the threshold voltage and the MOS-FET is not conducting. This allows the bus line at the “higher-voltage” section to be pulled up by its pull-up resistor R_p to 5 V. So the bus lines of both sections are HIGH, but at a different voltage level.
2. A 3.3 V device pulls down the bus line to a LOW level. The source of the MOS-FET also becomes LOW, while the gate stay at 3.3 V. V_{GS} rises above the threshold and the MOS-FET starts to conduct. The bus line of the “higher-voltage” section is then also pulled down to a LOW level by the 3.3 V device via the conducting MOS-FET. So the bus lines of both sections go LOW to the same voltage level.

3. A 5 V device pulls down the bus line to a LOW level. The drain-substrate diode of the MOS-FET the “lower-voltage” section is pulled down until V_{GS} passes the threshold and the MOS-FET starts to conduct. The bus line of the “lower-voltage” section is then further pulled down to a LOW level by the 5 V device via the conducting MOS-FET. So the bus lines of both sections go LOW to the same voltage level.

The three states show that the logic levels are transferred in both directions of the bus system, independent of the driving section. State 1 performs the level shift function. States 2 and 3 perform a “wired AND” function between the bus lines of both sections as required by the I²C-bus specification.

Supply voltages other than 3.3 V for V_{DD1} and 5 V for V_{DD2} can also be applied, e.g. 2 V for V_{DD1} and 10 V for V_{DD2} is feasible. In normal operation V_{DD2} must be equal to or higher than V_{DD1} (V_{DD2} is allowed to fall below V_{DD1} during switching power on/off).

The I²C-bus specification

19 DEVELOPMENT TOOLS AVAILABLE FROM PHILIPS

Table 8 I²C evaluation boards

PRODUCT	DESCRIPTION
OM4151/ S87C00KSD	I ² C-bus evaluation board with microcontroller, LCD, LED, Par. I/O, SRAM, EEPROM, Clock, DTMF generator, AD/DA conversion.
OM5500	Demo kit for the PCF2166 LCD driver and PCD3756A telecom microcontroller

Table 9 Development tools for 80C51-based systems

PRODUCT	DESCRIPTION
PDS51	A board-level, full featured, in-circuit emulator: RS232 interface to PC, universal motherboard, controlled via terminal emulation

Table 10 Development tools for 68000-based systems

PRODUCT	DESCRIPTION
OM4160/2	Microcore-2 demonstration/evaluation board with SCC68070
OM4160/4	Microcore-4 demonstration/evaluation board with 90CE201
OM4160/5	Microcore-5 demonstration/evaluation board with 90CE301

Table 11 I²C analyzers

PRODUCT	DESCRIPTION
OM1022	PC I ² C-bus analyzer with multi-master capability. Hardware and software (runs on IBM or compatible PC) to experiment with and analyze the behaviour of the I ² C-bus (includes documentation)
OM4777	Similar to OM1022 but for single-master systems only
PF8681	I ² C-bus analyzer support package for the PM3580 logic analyzer family

The I²C-bus specification

20 SUPPORT LITERATURE

Table 12 Data handbooks

TITLE	ORDERING CODE
IC01: Semiconductors for Radio, Audio and CD/DVD Systems	9397 750 02453
IC02: Semiconductors for Television and Video Systems	9397 750 01989
IC03: Semiconductors for Wired Telecom Systems (parts a & b)	9397 750 00839, 9397 750 00811
IC12: I ² C Peripherals	9397 750 01647
IC14: 8048-based 8-bit microcontrollers	9398 652 40011
IC17: Semiconductors for wireless communications	9397 750 01002
IC18: Semiconductors for in-car electronics	9397 750 00418
IC19: ICs for data communications	9397 750 00138
IC20: 80C51-based 8-bit microcontrollers + Application notes and Development tools	9397 750 00963
IC22: Multimedia ICs	9397 750 02183

Table 13 Brochures/leaflets/lab. reports/books etc.

TITLE	ORDERING CODE
Can you make the distance... with I ² C-bus (information about the P82B715 I ² C-bus extender IC)	9397 750 00008
I ² C-bus multi-master & single-master controller kits	9397 750 00953
Desktop video (CD-ROM)	9397 750 00644
80C51 core instructions quick reference	9398 510 76011
80C51 microcontroller selection guide	9397 750 01587
OM5027 I ² C-bus evaluation board for low-voltage, low-power ICs & software	9398 706 98011
P90CL301 I ² C driver routines	AN94078
User manual of Microsoft Pascal I ² C-bus driver (MICDRV4.OBJ)	ETV/IR8833
C routines for the PCF8584	AN95068
Using the PCF8584 with non-specified timings and other frequently asked questions	AN96040
User's guide to I ² C-bus control programs	ETV8835
The I ² C-bus from theory to practice (book and disk)	Author: D. Paret Publisher: Wiley ISBN: 0-471-96268-6
Bi-directional level shifter for I ² C-bus and other systems	AN97055
OM5500 demo kit for the PCF2166 LCD driver and PCD3756A telecom microcontroller	9397 750 00954

For more information about Philips Semiconductors and how we can help with your I²C-bus design, contact your nearest Philips Semiconductors national organization from the address list of the back of this book, or visit our worldwide web site at <http://www.semiconductors.philips.com/i2c> for the latest products, news and applications notes.

射频和天线设计培训课程推荐

易迪拓培训(www.edatop.com)由数名来自于研发第一线的资深工程师发起成立,致力并专注于微波、射频、天线设计研发人才的培养;我们于 2006 年整合合并微波 EDA 网(www.mweda.com),现已发展成为国内最大的微波射频和天线设计人才培养基地,成功推出多套微波射频以及天线设计经典培训课程和 ADS、HFSS 等专业软件使用培训课程,广受客户好评;并先后与人民邮电出版社、电子工业出版社合作出版了多本专业图书,帮助数万名工程师提升了专业技术能力。客户遍布中兴通讯、研通高频、埃威航电、国人通信等多家国内知名公司,以及台湾工业技术研究院、永业科技、全一电子等多家台湾地区企业。

易迪拓培训课程列表: <http://www.edatop.com/peixun/rfe/129.html>



射频工程师养成培训课程套装

该套装精选了射频专业基础培训课程、射频仿真设计培训课程和射频电路测量培训课程三个类别共 30 门视频培训课程和 3 本图书教材;旨在引领学员全面学习一个射频工程师需要熟悉、理解和掌握的专业知识和研发设计能力。通过套装的学习,能够让学员完全达到和胜任一个合格的射频工程师的要求...

课程网址: <http://www.edatop.com/peixun/rfe/110.html>

ADS 学习培训课程套装

该套装是迄今国内最全面、最权威的 ADS 培训教程,共包含 10 门 ADS 学习培训课程。课程是由具有多年 ADS 使用经验的微波射频与通信系统设计领域资深专家讲解,并多结合设计实例,由浅入深、详细而又全面地讲解了 ADS 在微波射频电路设计、通信系统设计和电磁仿真设计方面的内容。能让您在最短的时间内学会使用 ADS,迅速提升个人技术能力,把 ADS 真正应用到实际研发工作中去,成为 ADS 设计专家...

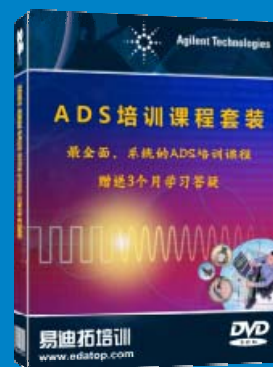

课程网址: <http://www.edatop.com/peixun/ads/13.html>



HFSS 学习培训课程套装

该套课程套装包含了本站全部 HFSS 培训课程,是迄今国内最全面、最专业的 HFSS 培训教程套装,可以帮助您从零开始,全面深入学习 HFSS 的各项功能和在多个方面的工程应用。购买套装,更可超值赠送 3 个月免费学习答疑,随时解答您学习过程中遇到的棘手问题,让您的 HFSS 学习更加轻松顺畅...

课程网址: <http://www.edatop.com/peixun/hfss/11.html>

CST 学习培训课程套装

该培训套装由易迪拓培训联合微波 EDA 网共同推出,是最全面、系统、专业的 CST 微波工作室培训课程套装,所有课程都由经验丰富的专家授课,视频教学,可以帮助您从零开始,全面系统地学习 CST 微波工作的各项功能及其在微波射频、天线设计等领域的设计应用。且购买该套装,还可超值赠送 3 个月免费学习答疑...

课程网址: <http://www.edatop.com/peixun/cst/24.html>



HFSS 天线设计培训课程套装

套装包含 6 门视频课程和 1 本图书,课程从基础讲起,内容由浅入深,理论介绍和实际操作讲解相结合,全面系统的讲解了 HFSS 天线设计的全过程。是国内最全面、最专业的 HFSS 天线设计课程,可以帮助您快速学习掌握如何使用 HFSS 设计天线,让天线设计不再难...

课程网址: <http://www.edatop.com/peixun/hfss/122.html>

13.56MHz NFC/RFID 线圈天线设计培训课程套装

套装包含 4 门视频培训课程,培训将 13.56MHz 线圈天线设计原理和仿真设计实践相结合,全面系统地讲解了 13.56MHz 线圈天线的工作原理、设计方法、设计考量以及使用 HFSS 和 CST 仿真分析线圈天线的具体操作,同时还介绍了 13.56MHz 线圈天线匹配电路的设计和调试。通过该套课程的学习,可以帮助您快速学习掌握 13.56MHz 线圈天线及其匹配电路的原理、设计和调试...

详情浏览: <http://www.edatop.com/peixun/antenna/116.html>



我们的课程优势:

- ※ 成立于 2004 年,10 多年丰富的行业经验,
- ※ 一直致力并专注于微波射频和天线设计工程师的培养,更了解该行业对人才的要求
- ※ 经验丰富的一线资深工程师讲授,结合实际工程案例,直观、实用、易学

联系我们:

- ※ 易迪拓培训官网: <http://www.edatop.com>
- ※ 微波 EDA 网: <http://www.mweda.com>
- ※ 官方淘宝店: <http://shop36920890.taobao.com>