

MAS9125**5 Outputs LDO Voltage Regulator IC**

- **Five Low Dropout Voltage Regulators**
- **Enable/Disable Control Pin for Each Regulator**
- **Common Control Pin to Shutdown The Whole Circuit**
- **All Outputs Ultra Low Noise**
- **Excellent Ripple Rejection**
- **Very Low Quiescent Current**
- **Thermal and Current Limiting Protection**

DESCRIPTION

The MAS9125 is a voltage regulator IC with five 2.8 V ultra low noise LDO regulators. Each regulator has its own independent enable/disable control pin. Additionally, all the outputs can be turned off by using a common control pin, which overrides regulator specific control pins. The highest output current is 150 mA (for the output 4). MAS9125 features a very low quiescent current: max 5 μ A in Off State and 90 μ A in On State. The dropout voltage is typically 0.11 V for outputs 1, 2, 3, and 5 and 0.17 V for output 4. The regulators 1, 2, and 3 have a common power supply pin marked as VCC_1. VCC_2 functions as a power supply pin for the regulators 4 and 5.

MAS9125 excels especially in noise performance and ripple rejection. Since all the outputs exhibit ultra low noise, noise sensitive circuitry can be driven by any of them. With high ripple rejection, MAS9125 effectively shields downstream electronics against power line disturbances.

An internal thermal protection circuit prevents the device from overheating. The maximum output current is limited internally, too.

FEATURES

- 2.8 V Regulators at 30 mA, 40 mA, 50 mA, 150 mA, and 60 mA
- Excellent Ripple Rejection: 72 dB Typical at 1 kHz, and 52 dB Typical at 10 kHz
- Ultra Low Noise: 21 μ Vrms Typical and 30 μ Vrms Maximum for All Regulators over Frequency Range 100 Hz...100 kHz
- Fast Dynamic Response
- Output Voltage Accuracy $<\pm 1.7\%$ at 27 °C
- 100 nF for Output Capacitors 1, 2, 4, and 5 and 1 μ F for Output Capacitor 3
- Separate Enable/Disable Control for Each Output
- Common Control Pin to Shutdown the Whole IC
- Very Low Quiescent Current: Maximum 5 μ A in Off State (Independent & Common Controls Off), Typical 90 μ A in On State (Common Control On, Independent Controls Off)
- TSSOP16 Package
- Functionally and Pin Compatible with MC33765

APPLICATIONS

- Mobile Phones
- Cordless Phones
- Portable Systems
- Battery Powered Systems
- Systems Needing Stabilized Power in Separate Blocks

BLOCK DIAGRAM

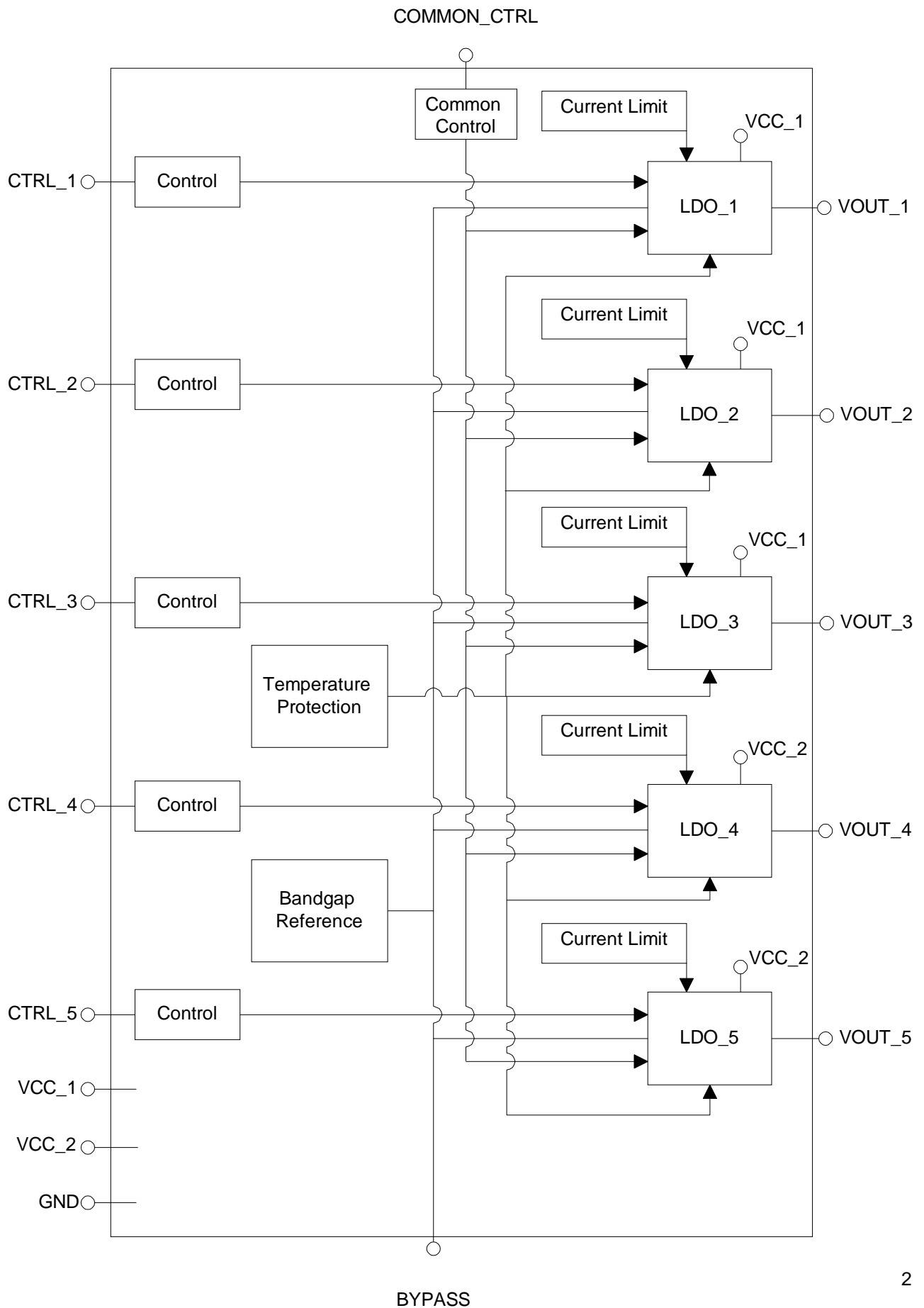

PIN CONFIGURATION & TOP MARKING

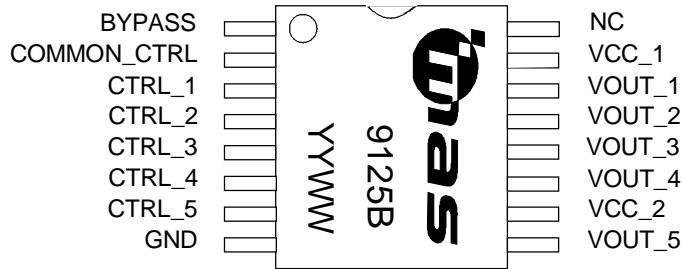

Top Marking Definitions:
YYWW = Year Week

PIN DESCRIPTION

Pin Name	Pin	Type	Function
BYPASS	1	I	Noise Bypass
COMMON_CTRL	2	I	Control Pin to Shutdown the Whole IC (Logic 0 = Shutdown, Logic 1 = Enable Regulator Specific Control Pins)
CTRL_1	3	I	Enable/Disable Control for Regulator 1
CTRL_2	4	I	Enable/Disable Control for Regulator 2
CTRL_3	5	I	Enable/Disable Control for Regulator 3
CTRL_4	6	I	Enable/Disable Control for Regulator 4
CTRL_5	7	I	Enable/Disable Control for Regulator 5
GND	8	P	Ground
VOUT_5	9	O	2.8 V/60 mA Regulator Output
VCC_2	10	P	Power Supply Voltage
VOUT_4	11	O	2.8 V/150 mA Regulator Output
VOUT_3	12	O	2.8 V/50 mA Regulator Output
VOUT_2	13	O	2.8 V/40 mA Regulator Output
VOUT_1	14	O	2.8 V/30 mA Regulator Output
VCC_1	15	P	Power Supply Voltage
NC	16		Not Connected

I = Input, O = Output, P = Power

ABSOLUTE MAXIMUM RATINGS

All Voltages with Respect to Ground

Parameter	Symbol	Conditions	Min	Max	Unit
Power Supply Voltage	V_{CC}			6	V
Thermal Resistance (Junction-to-Air)	$R_{\theta JA}$			144	°C/W
Operating Junction Temperature				125	°C
Junction Temperature	T_J			175	°C
Operating Ambient Temperature	T_A		-40	+85	°C
Storage Temperature	T_S		-55	+150	°C

Stresses beyond those listed may cause permanent damage to the device. The device may not operate under these conditions, but will not be destroyed.

ELECTRICAL CHARACTERISTICS

 For typical values $T_A = 27^\circ\text{C}$, for min/max values $T_A = -40^\circ\text{C}$ to $+85^\circ\text{C}$, unless otherwise noted

◆ Thermal Protection

Parameter	Symbol	Conditions	Min	Typ	Max	Unit
Threshold High	T_H		150	160	170	°C
Threshold Low	T_L		140	150	160	°C

A hysteresis of 10°C prevents oscillation in case of thermal shutdown. After the regulator temperature has dropped by this value, it will turn on again automatically.

◆ Common Control Pin Parameters

Parameter	Symbol	Conditions	Min	Typ	Max	Unit
Input Voltage ON-state OFF-state	V_{C-CTRL}		0 2.0		V_{CC} 0.3	V

◆ Single Regulator Control Pin Parameters

Parameter	Symbol	Conditions	Min	Typ	Max	Unit
Input Voltage ON-state OFF-state	$V_{CTRL1..5}$		0 2.0		V_{CC} 0.3	V

◆ Current Parameters

Parameter	Symbol	Conditions	Min	Typ	Max	Unit
Regulator 1 Output Current	I_{OUT1}	Listed maximum output currents are peak values. Maximum power dissipation should be used to determine the maximum total DC current.	0.5		30	mA
Regulator 2 Output Current	I_{OUT2}		0.5		40	mA
Regulator 3 Output Current	I_{OUT3}		0		50	mA
Regulator 4 Output Current	I_{OUT4}		0.5		150	mA
Regulator 5 Output Current	I_{OUT5}		0.5		60	mA
Current Limit	$I_{MAX1..5}$	I_{OUT} refers to each regulators' maximum output current $I_{OUT1..5}$		$3 \times I_{OUT}$		mA
Quiescent Current	I_{QOFF}	$I_{OUT} = 0 \text{ A}$, $V_{C-CTRL} < 0.3 \text{ V}$, $V_{CTRL1..5} < 0.3 \text{ V}$			5	μA
Quiescent Current	I_{QON}	$I_{OUT} = 0 \text{ A}$, $V_{C-CTRL} > 2.0 \text{ V}$, $V_{CTRL1..5} > 2.0 \text{ V}$		500		μA
Quiescent Current	I_{QC-ON}	$I_{OUT} = 0 \text{ A}$, $V_{C-CTRL} > 2.0 \text{ V}$, $V_{CTRL1..5} < 0.3 \text{ V}$		90		μA
Total RMS Output Current	I_{RMS}	$T_A = 85 \text{ }^\circ\text{C}$, $V_{CC} = 5.3 \text{ V}$			110	mA
Total RMS Output Current	I_{RMS}	$T_A = 25 \text{ }^\circ\text{C}$, $V_{CC} = 5.3 \text{ V}$			250	mA

◆ Power Dissipation

Parameter	Symbol	Conditions	Min	Typ	Max	Unit
Power Dissipation	P_d	$V_{CC} = 5.3 \text{ V}$, $T_A = 85 \text{ }^\circ\text{C}$			285	mW
Power Dissipation	P_d	$V_{CC} = 5.3 \text{ V}$, $T_A = 25 \text{ }^\circ\text{C}$			700	mW

◆ Voltage Parameters

Parameter	Symbol	Conditions	Min	Typ	Max	Unit
Supply Voltage	$V_{CC1..2}$		3.0	3.6	5.3	V
Output Voltage	$V_{OUT1..5}$		2.7	2.8	2.85	V
Regulator 1 Dropout Voltage	V_{DROP1}	$I_{OUT1} = 25 \text{ mA}$ for Typical V_{DROP1} $I_{OUT1} = \text{Max}$ for Max V_{DROP1}		0.11	0.17	V
Regulator 2 Dropout Voltage	V_{DROP2}	$I_{OUT2} = 35 \text{ mA}$ for Typical V_{DROP2} $I_{OUT2} = \text{Max}$ for Max V_{DROP2}		0.11	0.17	V
Regulator 3 Dropout Voltage	V_{DROP3}	$I_{OUT3} = 40 \text{ mA}$ for Typical V_{DROP3} $I_{OUT3} = \text{Max}$ for Max V_{DROP3}		0.11	0.17	V
Regulator 4 Dropout Voltage	V_{DROP4}	$I_{OUT4} = 140 \text{ mA}$ for Typical V_{DROP4} $I_{OUT4} = \text{Max}$ for Max V_{DROP4}		0.17	0.30	V
Regulator 5 Dropout Voltage	V_{DROP5}	$I_{OUT5} = 40 \text{ mA}$ for Typical V_{DROP5} $I_{OUT5} = \text{Max}$ for Max V_{DROP5}		0.11	0.17	V

◆ External Capacitors

Parameter	Symbol	Conditions	Min	Typ	Max	Unit
Output Capacitors for Regulators 1, 2, 4, 5 Regulator 3	$C_{OUT1..5}$ C_{OUT3}		0.10 1		1	μF
Effective Series Resistance	ESR		0.05	1	3	Ω
Bypass Capacitor	C_{BYPASS}			100		nF

◆ Load Regulation

Parameter	Symbol	Conditions	Min	Typ	Max	Unit
Load Regulation		$V_{CC} = 3.6\text{ V}$, I_{OUT} from 0.5 mA to Max			0.5	$\frac{\text{mV}}{\text{mA}}$

◆ Line Regulation

Parameter	Symbol	Conditions	Min	Typ	Max	Unit
Line Regulation		$I_{OUT} = \text{Max}$, V_{CC} from 5.3 V to 3.6 V		0.15	1.2	mV

◆ Ripple Rejection

Parameter	Symbol	Conditions	Min	Typ	Max	Unit
Ripple Rejection		$V_{CC} = V_{OUT} + 0.8\text{ V}$, $I_{OUT1..5} = \text{Max}$ $C_{OUT1,2,4,5} = 100\text{ nF}$, $C_{OUT3} = 1\text{ }\mu\text{F}$ $C_{BYPASS} = 100\text{ nF}$				dB
Regulators 1, 2, 3, 5		$f = 1\text{ kHz}$	60	74		
Regulator 4		$f = 1\text{ kHz}$	58	72		
Regulators 1, 2, 3, 5		$f = 10\text{ kHz}$	42	54		
Regulator 4		$f = 10\text{ kHz}$	40	52		
Regulator 3		$f = 100\text{ kHz}$	26	38		
Regulators 1, 2, 4, 5		$f = 100\text{ kHz}$	22	34		

◆ Noise and Crosstalk

Parameter	Symbol	Conditions	Min	Typ	Max	Unit
Noise Voltage	V_{NO}	$100\text{ Hz} < f < 100\text{ kHz}$, $C_{BYPASS} = 100\text{ nF}$				μVrms
All Regulators		$C_{OUT1,2,4,5} = 100\text{ nF}$, $C_{OUT3} = 1\text{ }\mu\text{F}$		21	30	
Dynamic Crosstalk Attenuation		$f = 10\text{ kHz}$ (Note 1)	40			dB

Note 1: Dynamic Crosstalk is the ratio between a forced output signal to signal transferred to other outputs.

◆ Dynamic Parameters

Parameter	Symbol	Conditions	Min	Typ	Max	Unit
Rise Time (From Enable to V_{OUT} 90%, Common Control at ON state)		$V_{C-CTRL} > 2.0\text{ V}$, $V_{CTRL1..5}$ separately from $< 0.3\text{ V}$ to $> 2.0\text{ V}$				μs
Regulators 1,2,4,5		$C_{OUT1,2,4,5} = 100\text{ nF}$			30	
Regulator 3		$C_{OUT3} = 1\text{ }\mu\text{F}$			70	
Overshoot		$V_{C-CTRL} > 2.0\text{ V}$, $V_{CTRL1..5}$ separately from $< 0.3\text{ V}$ to $> 2.0\text{ V}$		1	8	%
		$C_{OUT1,2,4,5} = 100\text{ nF}$, $C_{OUT3} = 1\text{ }\mu\text{F}$				
Settling Time (from V_{OUT} 90% to max $\pm 0.1\%$ fluctuation)		$V_{C-CTRL} > 2.0\text{ V}$, $V_{CTRL1..5}$ separately from $< 0.3\text{ V}$ to $> 2.0\text{ V}$			70	μs
		$C_{1,2,4,5} = 100\text{ nF}$, $C_3 = 1\text{ }\mu\text{F}$				

OUTPUT NOISE PERFORMANCE FOR REGULATOR 3

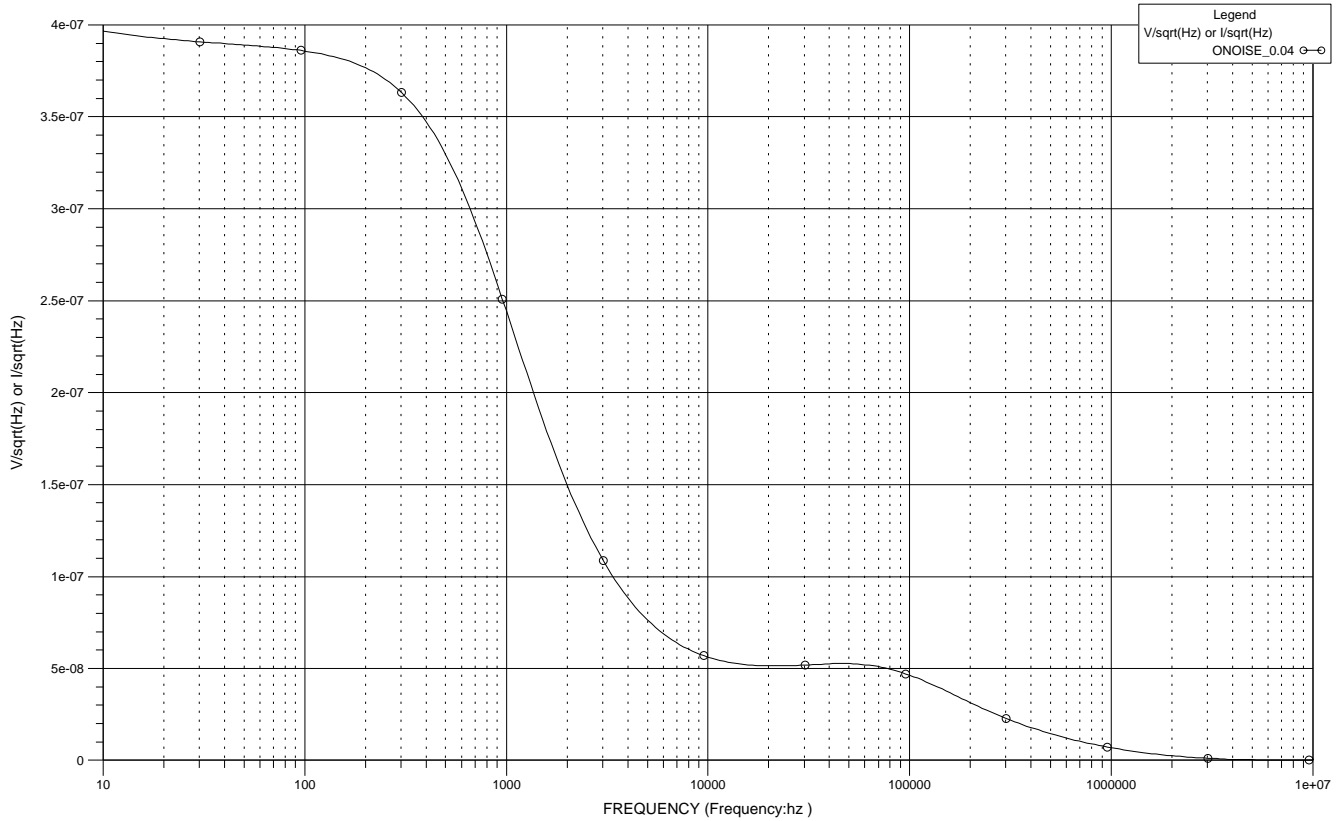

$V_{IN} = 3.6 \text{ V}$, $I_{OUT} = 40 \text{ mA}$, $C_{BYPASS} = 10 \text{ nF}$, $T_J = 27 \text{ }^\circ\text{C}$

APPLICATION INFORMATION

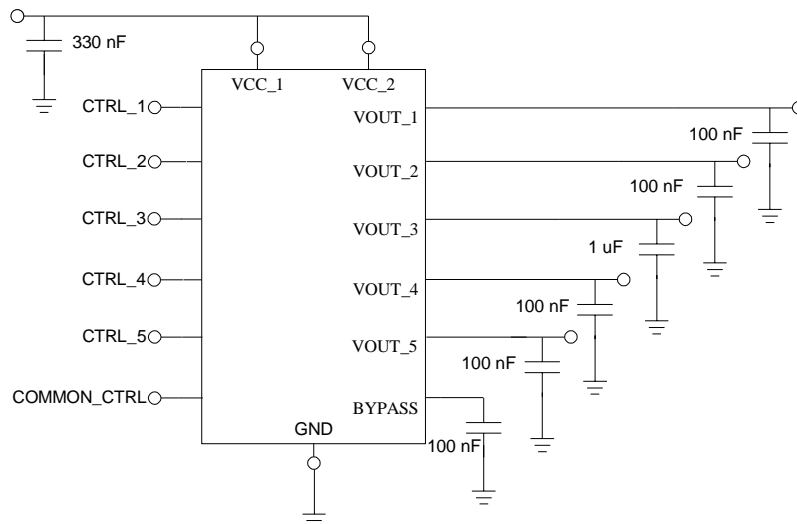

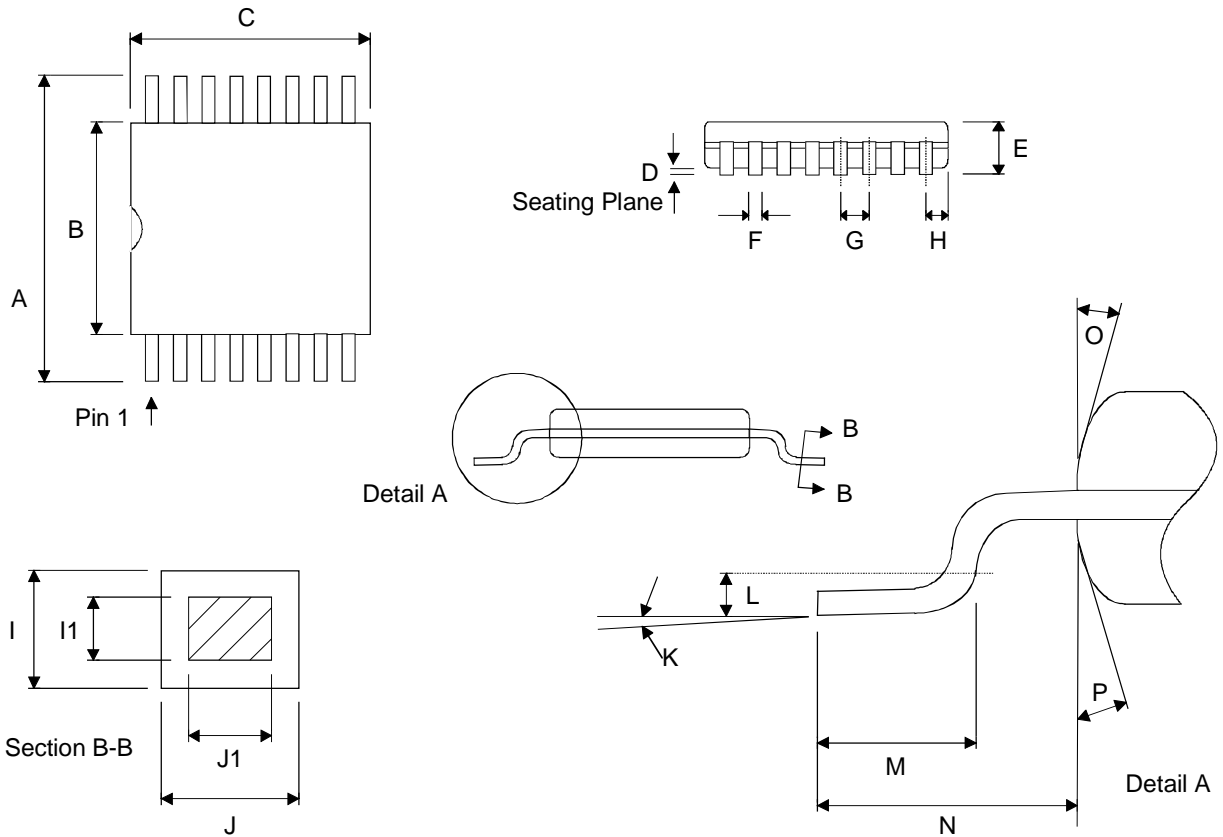
PACKAGE (TSSOP16) OUTLINES

Dimension	Min	Max	Unit
A	6.40 BSC		mm
B	4.30	4.50	mm
C	5.00 BSC		mm
D	0.05	0.15	mm
E		1.10	mm
F	0.19	0.30	mm
G	0.65 BSC		mm
H	0.18	0.28	mm
I	0.09	0.20	mm
I1	0.09	0.16	mm
J	0.19	0.30	mm
J1	0.19	0.25	mm
K	0°	8°	
L	0.24	0.26	mm
M	0.50	0.75	mm
(The length of a terminal for soldering to a substrate)			
N	1.00 REF		mm
O	12°		
P	12°		

Dimensions do not include mold flash, protrusions, or gate burrs.
 All dimensions are in accordance with JEDEC standard MO-153.

SOLDERING INFORMATION

Resistance to Soldering Heat	According to RSH test IEC 68-2-58/20 2*220°C
Maximum Temperature	240°C
Maximum Number of Reflow Cycles	2
Reflow profile	Thermal profile parameters stated in JESD22-A113 should not be exceeded. http://www.jedec.org
Seating Plane Co-planarity	max 0.08 mm
Lead Finish	Solder plate 7.62 - 25.4 μm, material Sn 85% Pb 15%

EMBOSSED TAPE SPECIFICATIONS

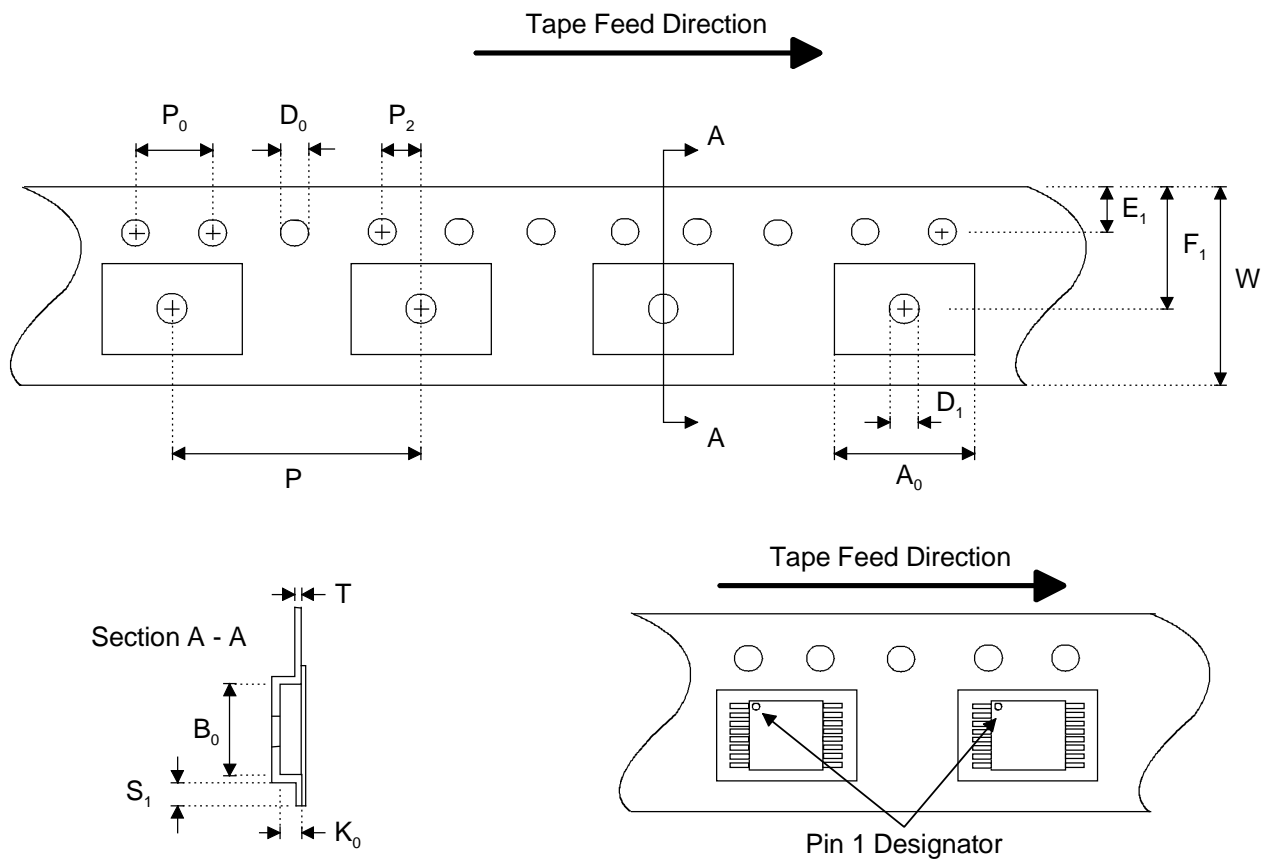

Dimension	Min	Max	Unit
A ₀	6.50	6.70	mm
B ₀	5.20	5.40	mm
D ₀	1.50 +0.10 / -0.00		mm
D ₁	1.50		mm
E ₁	1.65	1.85	mm
F ₁	7.20	7.30	mm
K ₀	1.20	1.40	mm
P	11.90	12.10	mm
P ₀	4.0		mm
P ₂	1.95	2.05	mm
S ₁	0.6		mm
T	0.25	0.35	mm
W	11.70	12.30	mm

REEL SPECIFICATIONS

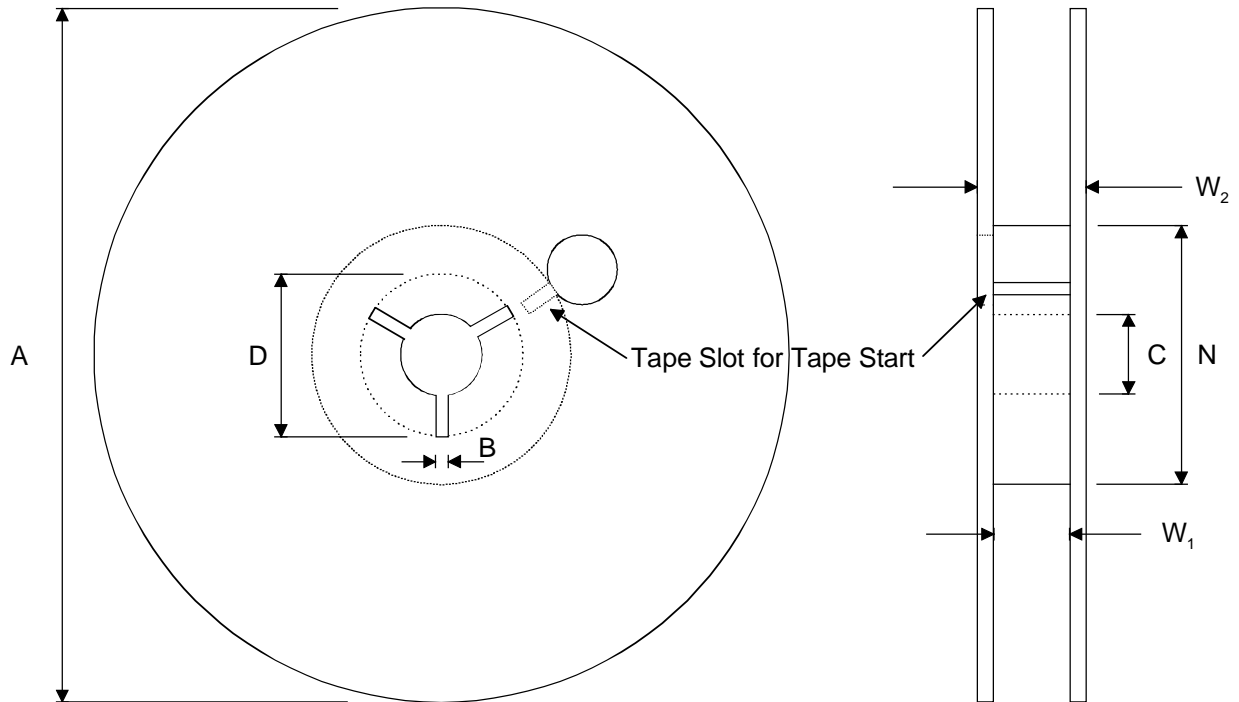

2000 Components on Each Reel

Reel Material: Conductive, Plastic Antistatic or Static Dissipative

Carrier Tape Material: Conductive

Cover Tape Material: Static Dissipative

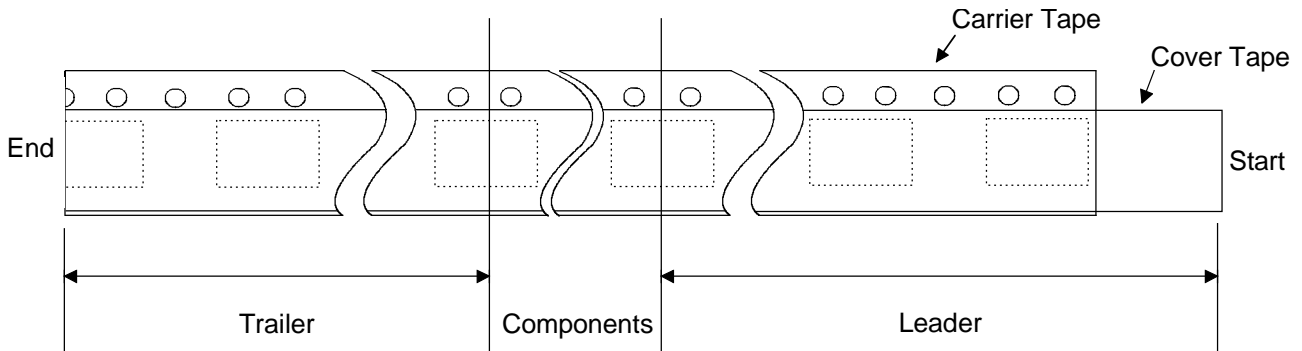

Dimension	Min	Max	Unit
A		330	mm
B	1.5		mm
C	12.80	13.50	mm
D	20.2		mm
N	50		mm
W_1 (measured at hub)	12.4	14.4	mm
W_2 (measured at hub)		18.4	mm
Trailer	160		mm
Leader	390, of which minimum 160mm of empty carrier tape sealed with cover tape		mm
Weight		1500	g

ORDERING INFORMATION

Product Code	Product	Package	Comments
MAS9125BUAC-T	LDO Voltage Regulator IC	TSSOP16	2k Units on Tape and Reel in Moisture Barrier Bag

LOCAL DISTRIBUTOR

MICRO ANALOG SYSTEMS OY CONTACTS

Micro Analog Systems Oy Kamreerintie 2, P.O.Box 51 FIN-02771 ESPOO, FINLAND http://www.mas-oy.com	Tel. (09) 80 521 Tel. Int. +358 9 80 521 Telefax +358 9 805 3213 E-mail: info@mas-oy.com
------------------------------------------------------------------------------------------------------------------------------------------------	----------------------------------------------------------------------------------------------------------------------------------------

NOTICE

Micro Analog Systems Oy reserves the right to make changes to the products contained in this data sheet in order to improve the design or performance and to supply the best possible products. Micro Analog Systems Oy assumes no responsibility for the use of any circuits shown in this data sheet, conveys no license under any patent or other rights unless otherwise specified in this data sheet, and makes no claim that the circuits are free from patent infringement. Applications for any devices shown in this data sheet are for illustration only and Micro Analog Systems Oy makes no claim or warranty that such applications will be suitable for the use specified without further testing or modification.

射频和天线设计培训课程推荐

易迪拓培训(www.edatop.com)由数名来自于研发第一线的资深工程师发起成立,致力并专注于微波、射频、天线设计研发人才的培养;我们于 2006 年整合合并微波 EDA 网(www.mweda.com),现已发展成为国内最大的微波射频和天线设计人才培养基地,成功推出多套微波射频以及天线设计经典培训课程和 ADS、HFSS 等专业软件使用培训课程,广受客户好评;并先后与人民邮电出版社、电子工业出版社合作出版了多本专业图书,帮助数万名工程师提升了专业技术能力。客户遍布中兴通讯、研通高频、埃威航电、国人通信等多家国内知名公司,以及台湾工业技术研究院、永业科技、全一电子等多家台湾地区企业。

易迪拓培训课程列表: <http://www.edatop.com/peixun/rfe/129.html>



射频工程师养成培训课程套装

该套装精选了射频专业基础培训课程、射频仿真设计培训课程和射频电路测量培训课程三个类别共 30 门视频培训课程和 3 本图书教材;旨在引领学员全面学习一个射频工程师需要熟悉、理解和掌握的专业知识和研发设计能力。通过套装的学习,能够让学员完全达到和胜任一个合格的射频工程师的要求...

课程网址: <http://www.edatop.com/peixun/rfe/110.html>

ADS 学习培训课程套装

该套装是迄今国内最全面、最权威的 ADS 培训教程,共包含 10 门 ADS 学习培训课程。课程是由具有多年 ADS 使用经验的微波射频与通信系统设计领域资深专家讲解,并多结合设计实例,由浅入深、详细而又全面地讲解了 ADS 在微波射频电路设计、通信系统设计和电磁仿真设计方面的内容。能让您在最短的时间内学会使用 ADS,迅速提升个人技术能力,把 ADS 真正应用到实际研发工作中去,成为 ADS 设计专家...



课程网址: <http://www.edatop.com/peixun/ads/13.html>



HFSS 学习培训课程套装

该套课程套装包含了本站全部 HFSS 培训课程,是迄今国内最全面、最专业的 HFSS 培训教程套装,可以帮助您从零开始,全面深入学习 HFSS 的各项功能和在多个方面的工程应用。购买套装,更可超值赠送 3 个月免费学习答疑,随时解答您学习过程中遇到的棘手问题,让您的 HFSS 学习更加轻松顺畅...

课程网址: <http://www.edatop.com/peixun/hfss/11.html>

CST 学习培训课程套装

该培训套装由易迪拓培训联合微波 EDA 网共同推出,是最全面、系统、专业的 CST 微波工作室培训课程套装,所有课程都由经验丰富的专家授课,视频教学,可以帮助您从零开始,全面系统地学习 CST 微波工作的各项功能及其在微波射频、天线设计等领域的设计应用。且购买该套装,还可超值赠送 3 个月免费学习答疑...

课程网址: <http://www.edatop.com/peixun/cst/24.html>



HFSS 天线设计培训课程套装

套装包含 6 门视频课程和 1 本图书,课程从基础讲起,内容由浅入深,理论介绍和实际操作讲解相结合,全面系统的讲解了 HFSS 天线设计的全过程。是国内最全面、最专业的 HFSS 天线设计课程,可以帮助您快速学习掌握如何使用 HFSS 设计天线,让天线设计不再难...

课程网址: <http://www.edatop.com/peixun/hfss/122.html>

13.56MHz NFC/RFID 线圈天线设计培训课程套装

套装包含 4 门视频培训课程,培训将 13.56MHz 线圈天线设计原理和仿真设计实践相结合,全面系统地讲解了 13.56MHz 线圈天线的工作原理、设计方法、设计考量以及使用 HFSS 和 CST 仿真分析线圈天线的具体操作,同时还介绍了 13.56MHz 线圈天线匹配电路的设计和调试。通过该套课程的学习,可以帮助您快速学习掌握 13.56MHz 线圈天线及其匹配电路的原理、设计和调试...

详情浏览: <http://www.edatop.com/peixun/antenna/116.html>



我们的课程优势:

- ※ 成立于 2004 年,10 多年丰富的行业经验,
- ※ 一直致力并专注于微波射频和天线设计工程师的培养,更了解该行业对人才的要求
- ※ 经验丰富的一线资深工程师讲授,结合实际工程案例,直观、实用、易学

联系我们:

- ※ 易迪拓培训官网: <http://www.edatop.com>
- ※ 微波 EDA 网: <http://www.mweda.com>
- ※ 官方淘宝店: <http://shop36920890.taobao.com>