

RF Impedance Measurement Basics

Greg Amorese

Hewlett-Packard Company
Kobe Instrument Division
1400 Fountain Grove Parkway
Santa Rosa, California 95403-1799
U.S.A.

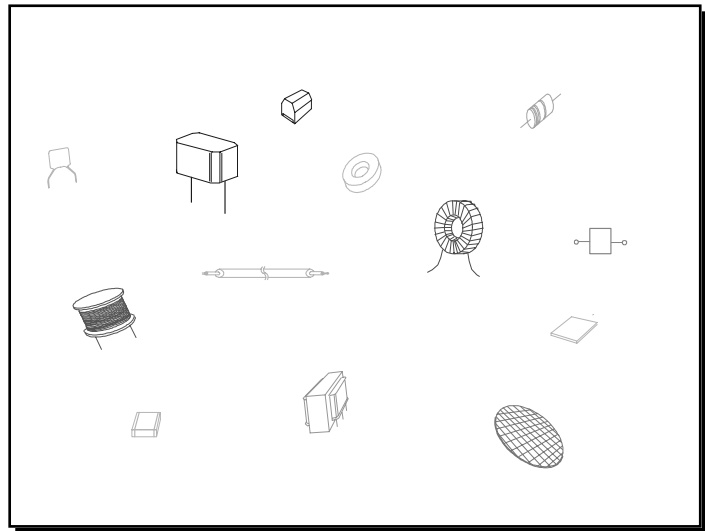

Back to Basics Seminar

Abstract

Today's circuit designers and component manufacturers need to make more demanding measurements on SMD (surface-mount devices) and other components. At the same time the components are becoming harder to measure accurately.

This module will review impedance, component value definitions, and present typical measurement problems and their solutions. Error correction and compensation techniques will be discussed. Finally, products and techniques for specific applications will be suggested.

Author

Greg Amorese joined Hewlett-Packard in 1979 as a Marketing Engineer at the Loveland Instrument Division in Colorado. He transferred to the Kobe Instrument Division (KID) in 1988 to work as their Product Line Manager at Hewlett-Packard's European Marketing Operation. He now works in Santa Rosa, California as the U.S. Sales Manager for KID.

RF / Impedance Measurement Basics

Slide #1

Making Quality RF Impedance Measurements



Back to Basics Seminar

Impedance measurements at Radio Frequencies (RF; e.g. the GHz range) are quite challenging. At these frequencies, physics creates some problems for us. The first major problem is what technique we will use to make the measurements. The second major problem is due to the need to have fixtures for the components which have significant parasitics at those higher frequencies. The third problem drops out of the prior two; i.e. how do we calibrate and compensate to get sensible, accurate results.

RF / Impedance Measurement Basics

Slide #2

Component Industry Trends

Driven by New End-User Equipment

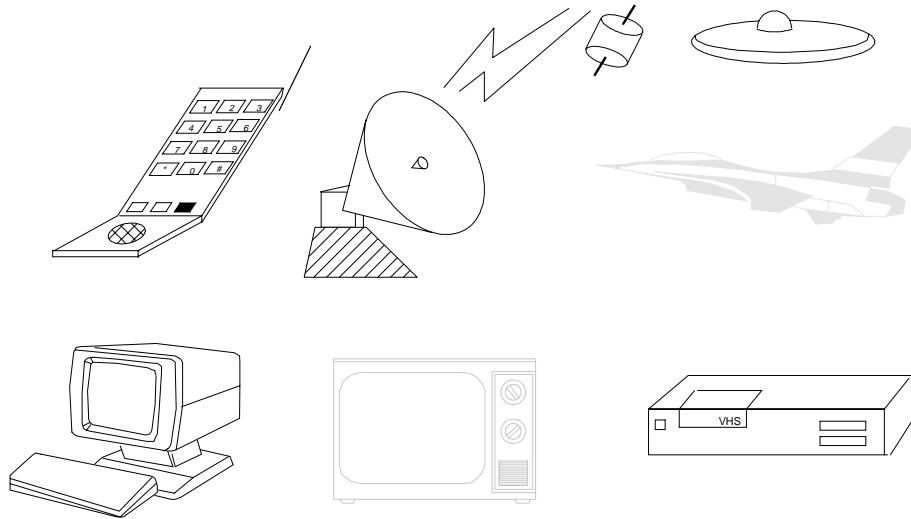

The need to measure components at RF is due to trends in the electronics industry; more and more equipment operating at higher frequencies and with more stringent requirements. The advent of SMD (Surface Mount Device) components is giving circuit designers the ability to meet their requirements if they can verify how those components actually will work in their circuits.

Slide #3

Requirements for RF Discrete Components

Trends

1. **Increased number of users**
2. **Longer operating time**
3. **Better durability**
4. **Smaller Size**
5. **Lower price**

**Requirements**

1. **Higher frequency operation**
2. **Lower loss components**
3. **Stable performance in wide environmental conditions**
4. **Chip Configuration**
5. **Lower price; higher reliability**

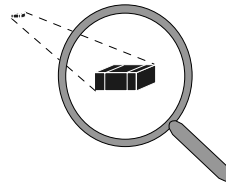

RF / Impedance Measurement Basics

Slide #4

Agenda

- ***Impedance Basics***
 - ***Definitions***
 - ***Parasitics***
 - ***Models***
- **Measurement Techniques**
- **Calibration, Compensation, and Port Extension**
- **Component Fixturing**
- **Summary**

First we will review the basics of impedance starting with definitions, then review the concept of parasitics, and describe the models that are used to define the component values that we normally use.

After that, we will review and position common impedance measurement techniques that are available. Then we will discuss in some detail calibration, compensation, port extension, and fixturing.

RF / Impedance Measurement Basics

Slide #5

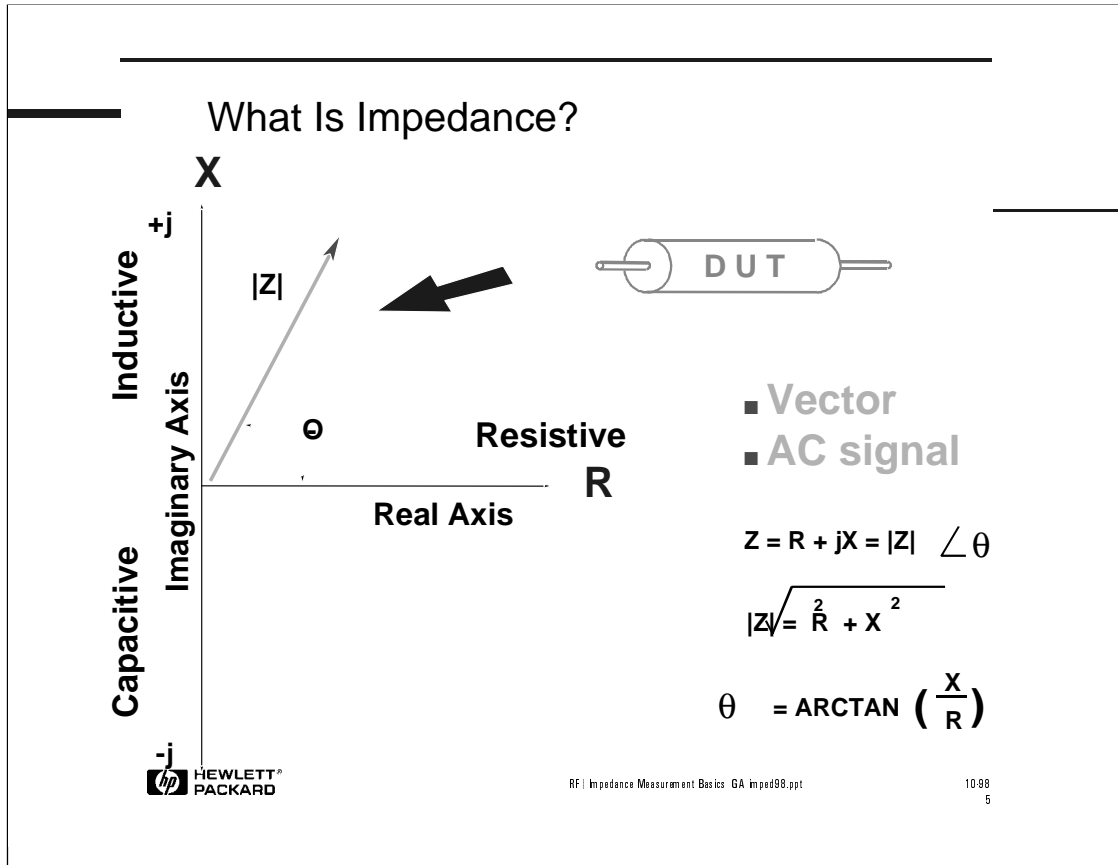

This is the definition of impedance. PERIODIC, in this case means an AC test signal as opposed to a static or DC test signal. So, amplitude and frequency should be considered. TOTAL includes both real and imaginary components. This obviously applies to simple components as well as to complex DUT, cables, amplifiers, etc. By definition, impedance is for the series model: $Z=R+jX$, where the real part R is the resistance and the imaginary part X the reactance. Similarly, admittance is for the parallel model: $Y=G+jB$, where G is the conductance and B the susceptance.

The impedance measurement plane can be visualized with the real element, or resistance, on the x-axis and the imaginary element, or reactance, on the y-axis. Ideal components would lie on an axis. Capacitors are typically found in the lower quadrant, while inductors are in the upper quadrant. The more ideal an inductor or a capacitor, the less resistive it will be, therefore the angle will be close to $+90^\circ$ or -90° .

RF / Impedance Measurement Basics

Slide #6

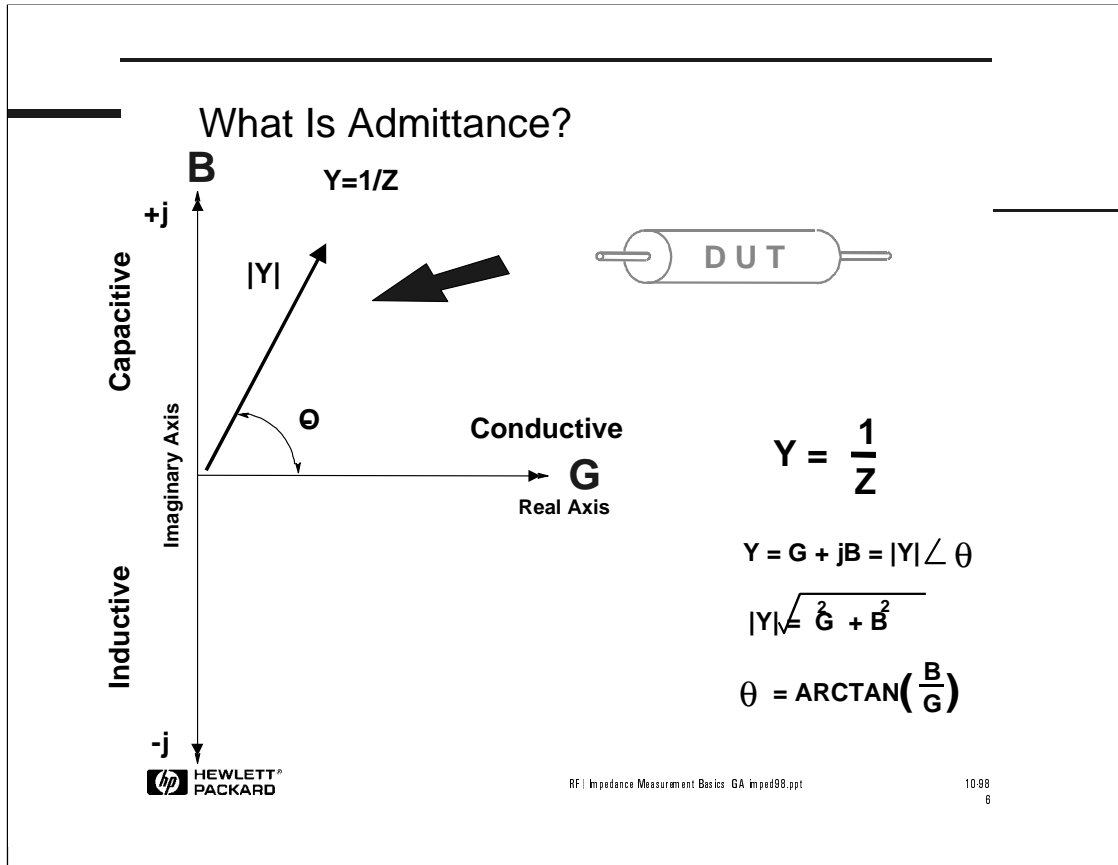

The admittance measurement plane can be visualized with the real element, or conductance, on the x-axis and the imaginary element, or susceptance, on the y-axis. Admittance is often used for capacitors since it helps to simplify the math. Additionally, it is commonly used for materials.

RF / Impedance Measurement Basics

Slide #7

What are Q Factor and D Factor?

- Different from the Q associated with resonators and filters
- $Q = \frac{\text{Energy stored}}{\text{Energy lost}} = \frac{X_s}{R_s}$
- The better the component, then
 $R \Rightarrow 0 \quad Q \Rightarrow \infty$
- $D = \frac{1}{Q}$, mainly used for capacitors

The quality factor Q for components differs from the Q associated to filters or resonators. For components, the quality factor serves as a measure of the reactance (or susceptance) purity. In the real world, there is always some associated resistance that dissipate power (lost power), decreasing the amount of energy that can be recovered. Note that Q is dimensionless and that it also represents the tangent of the impedance (or admittance) vector angle theta in the measurement plane. Q is generally used for inductors and D for capacitors.

Capacitors may have very high Q's (even over 10,000) while a Q value of 100 is considered very high for an inductor.

RF / Impedance Measurement Basics

Slide #8

Why Do We Need to Measure Impedance?

Component Parasitics

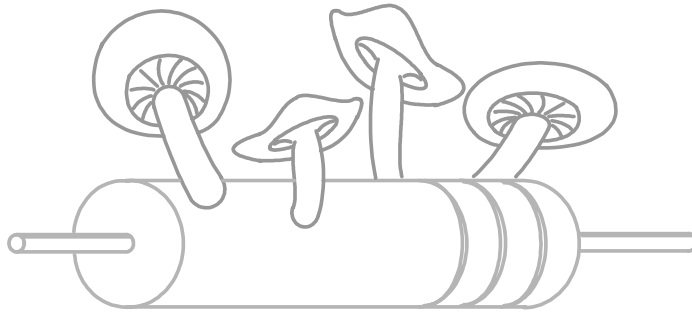

Well, the answer is simple: because all components have parasitics. The quality of component material and design determines the parasitics. Basically there is no perfect component in nature like purely resistive or reactive devices. They all have parasitics and therefore their behavior depends upon them. For instance, all components have frequency limitations.

RF / Impedance Measurement Basics

Slide #9

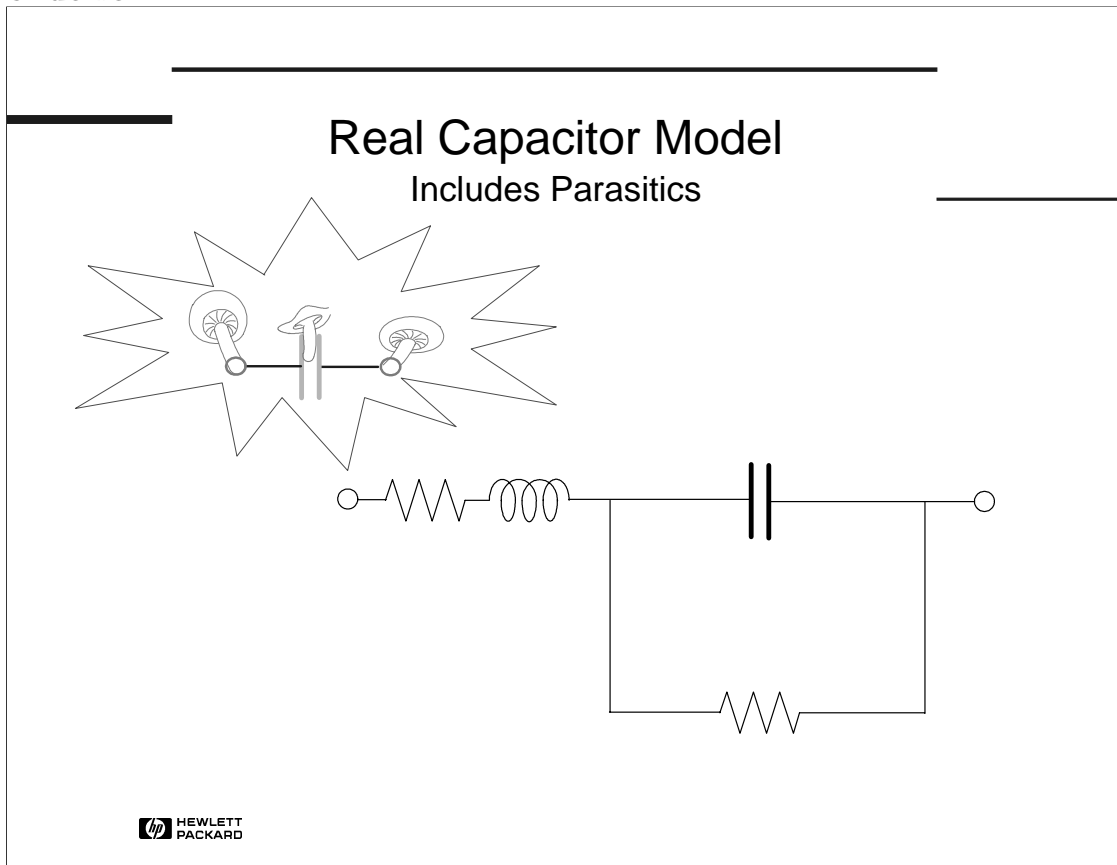

Let's examine a real world capacitor. The design and the quality of its material introduces parasitics. There are unwanted series wire inductance and resistance and unwanted resistance and capacitance across the dielectric. For example, this is a realistic capacitor model taking into account the parasitics. Can we quantify these parasitics? Certainly. The quality factor Q represents some of the component's non-ideal characteristics. The higher the Q , the better or more ideal the component.

RF / Impedance Measurement Basics

Slide #10

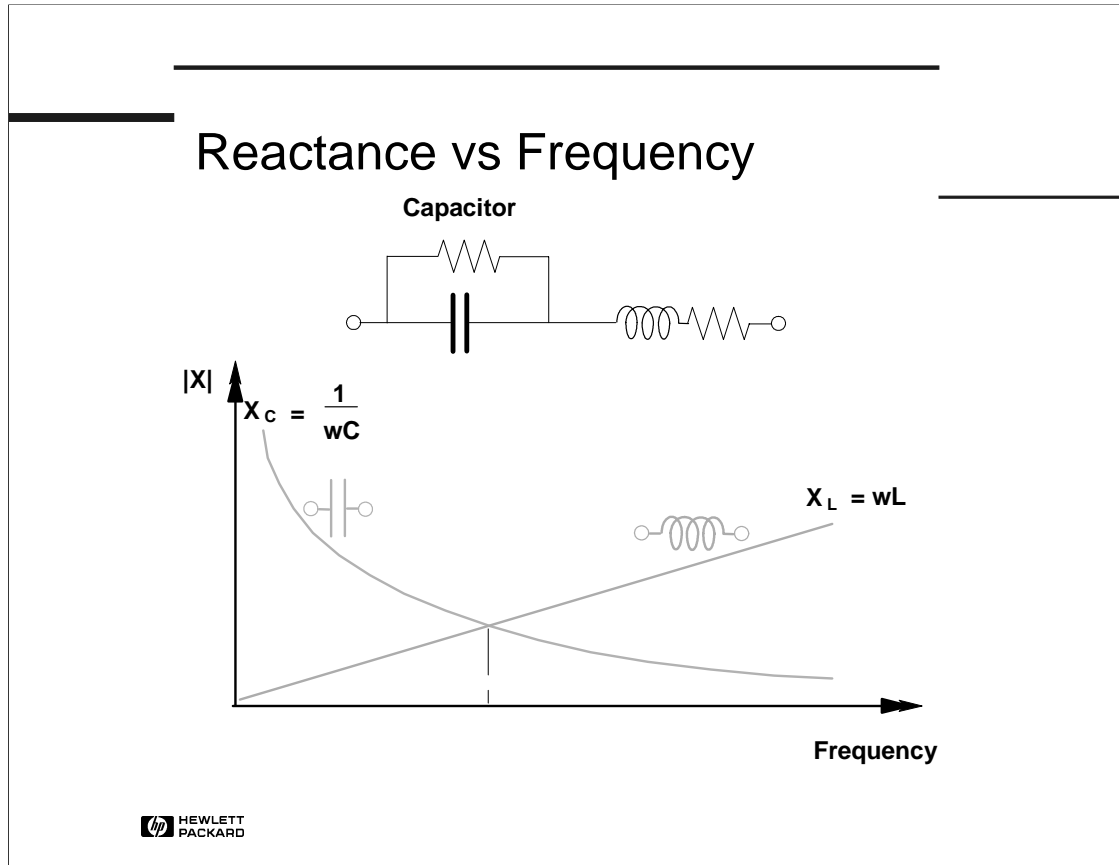

Frequency is the most significant dependency factor. The reactance of an ideal capacitor would vary like the X_c curve. We can oversimplify this real world capacitor model by neglecting the resistors and essentially take into account the series lead reactance X_L .

As a consequence, this capacitor looks like a capacitor in the lower frequency region. The point where the capacitive and inductive reactance are equal is the resonant frequency and the component behaves like a resistor. At higher frequencies, this capacitor behaves like an inductor!

RF / Impedance Measurement Basics

Slide #11

Impedance Measurement Example

Capacitor going through resonance

A: |Z| B: θ MKR 63 200 000.000 Hz
 A MAX 50.00 Ω MAG 47.2113 m Ω
 B MAX 100.0 deg PHASE 659.015 mdeg

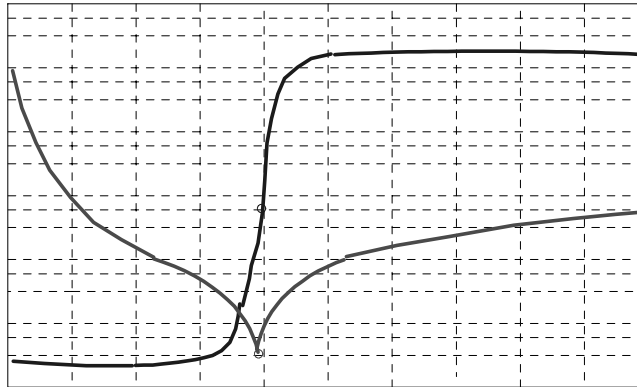

Capacitor
Characteristics

A MIN 20.00 m Ω START 10 000 000.000 Hz
 B MIN -100.0 deg STOP 150 000 000.000 Hz

This display shows Z and theta of a capacitor between 10 MHz and 150 MHz. Before resonance, the phase is around -90° and the component effectively looks like a capacitor. The impedance decreases with the frequency until the resonance point, due to the inductive elements of the component. Note that at resonance, the phase is 0° - purely resistive. After resonance the phase angle changes to $+90^\circ$ so the inductive elements dominate. Remember, when you buy a capacitor, you get three components!

RF / Impedance Measurement Basics

Slide #12

L vs. DC Current Bias Level Power Inductors

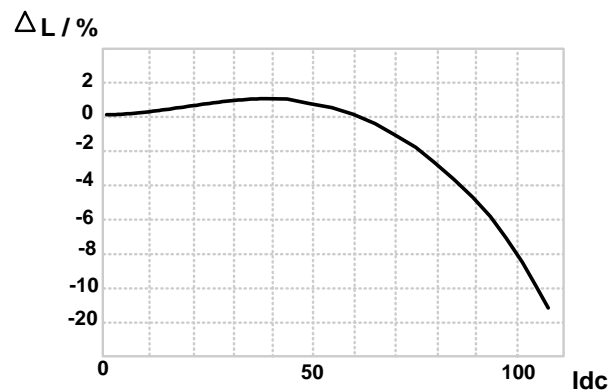

We all remember that most inductive components have parasitics that affect their performance with different current or voltage levels. This is due to the physics of the magnetic material used in these devices.

It is important to understand these characteristics. For example, switching power supplies are very common today. They use power inductors for filtering the RFI and the noise produced by high currents. To maintain good filtering and ripple at high current levels, power inductors must be tested at operating conditions to ensure that the inductance roll-off does not affect the performance.

RF / Impedance Measurement Basics

Slide #13

New SMD Components Have New Parasitics

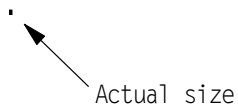

(0402; next generation is 0201)

What you see above is our best attempt to show you the size of some of the state-of-the-art components. We can find both RF capacitors and inductors in this size (0402). We are now starting to see capacitors $\frac{1}{4}$ that size (0201) coming off the production line.

RF / Impedance Measurement Basics

Slide #14

C Variation with Signal Level

C vs DC Voltage Bias

Type I and II SMD Capacitors

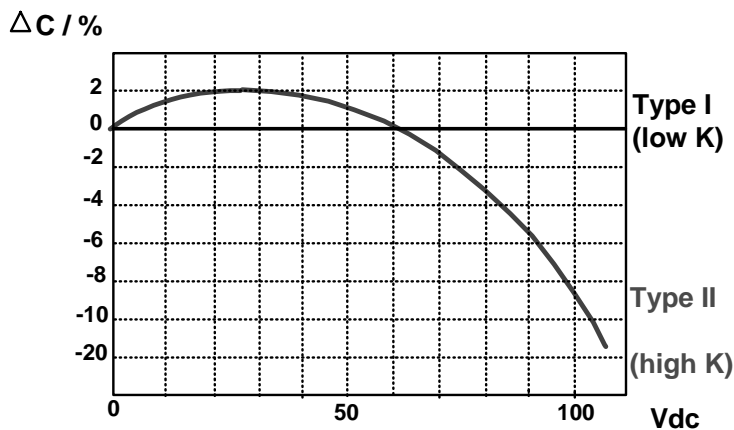

But you don't get this small size for free. In our circuit design we may still need a fairly high value capacitor, but we want it in a small size. To achieve that, some capacitors are using new dielectric materials that have a high dielectric constant which have other parasitics. So frequency is not the only factor influencing the behavior of components. For instance, the AC signal level is a very important dependency factor for these SMD's.

DC biasing can also change a component's value. It's important to take it into account when designing circuits. For choosing an SMD, DC bias voltage is a crucial parameter to insure the right performance. Type II SMD capacitors are more and more popular because of their high dielectric constant material, like X7R, Y5V or Z5U, which allows larger capacitance per unit volume. But their capacitance varies more with DC biasing than for Type I SMD capacitors.

RF / Impedance Measurement Basics

Slide #15

C Variation with Signal Level

C vs AC Test Signal Level
SMD Capacitors, Various dielectric constants K

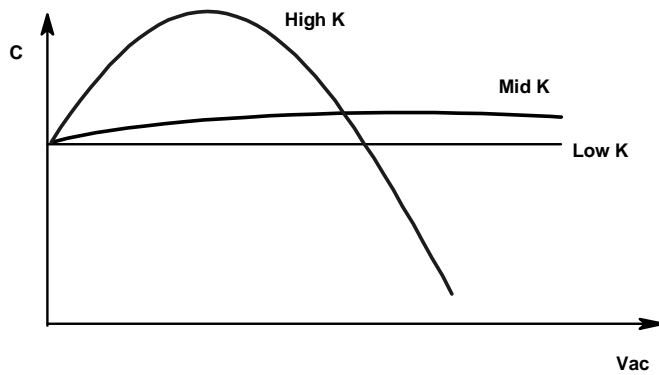

RF / Impedance Measurement Basics

Slide #16

What Do Instruments...

Measure ?

Calculate ?

Approximate ?

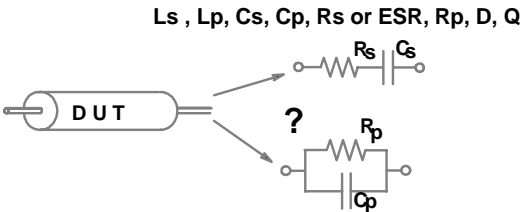
	I-V Method	Reflection Coefficient Method $\Gamma_{x,y}$
Measured	I, V	
Direct Calculations	$Z = \frac{V}{I}$	$Z = Z_0 \frac{1 + \Gamma}{1 - \Gamma}$
Model based Approximations	<p style="margin: 0;">Ls , Lp, Cs, Cp, Rs or ESR, Rp, D, Q</p> 	



Since all real world components have parasitics, we must lump all the resistive and reactive elements of the component together into an equivalent set of series or parallel elements. These 2 circuit modes allow the instrument to interpret the measurement data and translate it into indicated value according to the user's information (model choice).

Impedance cannot be directly measured like voltage, for instance. The fundamental parameter measured by the instrument depends upon the instrument technique. Then the internal processor makes a direct calculation to compute Z, Y. But usually users ask for parameters like L, C, R, D or Q, which can be derived from simple two element models (series and parallel ones). These are approximate models used to describe the component's behavior. Let's see how these approximations have been made.

RF / Impedance Measurement Basics

Slide #17

Circuit Mode

Requires Simplified Models

Complete Capacitor Model
Rs, Ls, Rp, Cp ?

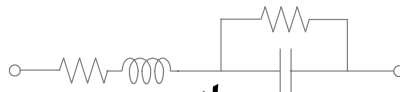

No L Capacitor Model

TOO COMPLEX

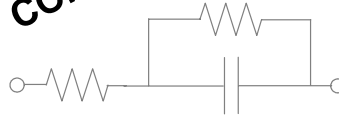

This complete capacitor model represents the effective value of this capacitor. Obviously, the model depends on the capacitor technology and is tuned through experiments and circuit simulation. It is possible to measure the global Z , θ , R , or X of the real capacitor, but it is too complicated for what users want to see. Therefore, all instruments have built-in two-element models: i.e. R_s , C_s , or series model, and R_p , C_p , or parallel model, for capacitors.

RF / Impedance Measurement Basics

Slide #18

Circuit Mode

R_s vs R_p , who wins ?

No L Capacitor Model

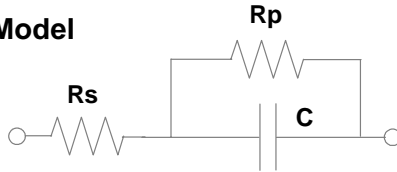

Series model



Large C

Small L

Parallel model

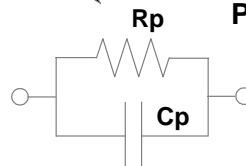

Small C

Large L

SMD

Let us see how to simplify the model and come up with the best approximation. Let's assume that the lead inductance is negligible. Then this new model consists of a perfect capacitor and a series resistor, R_s , as well as a parallel one, R_p . Usually R_s is in the ohms or milli-ohms while R_p is in the mega-ohms or greater.

For large C or low impedance devices, the loss due to the series resistance R_s is more significant than the leakage loss due to the parallel resistor R_p . Therefore the Series Model is convenient for large capacitors, while the Parallel Model fits the small capacitors. But what is large and what is small? Typically, large capacitors are 100 μF and greater and small ones are 10 μF and below. However, for SMD capacitors, the parallel model is always better because of very low contact resistance, R_s , and inductance, L_s . On the other hand, we will use the parallel model for large inductors and the series model for small ones.

RF / Impedance Measurement Basics

Slide #19

Which Model is Correct ?

- Both are correct

$$C_s = C_p (1 + D)^2$$

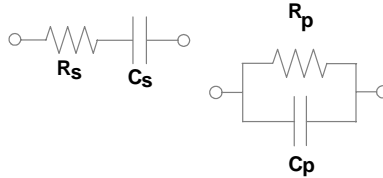

- One is a better approximation
- For high Q or low D components,
 $C_s \approx C_p$

Since the user tells the instrument which model to use, this is a source of measurement discrepancy. Fortunately, both models are always correct and related to each other through this math formula. For low quality devices, one model is always a better approximation, while high quality or low dissipation DUTs exhibit identical series or parallel values ($D \ll 1$).

RF / Impedance Measurement Basics

Slide #20

Equivalent Circuit Analysis Yields More Accurate Models

EQUIVALENT CIRCUIT MODE
SELECTED : D

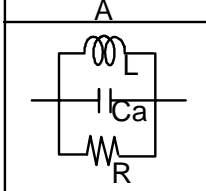
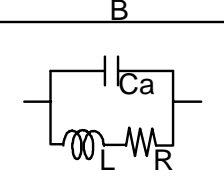
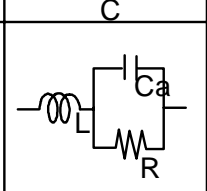
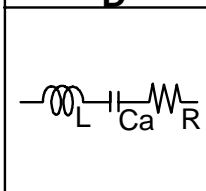
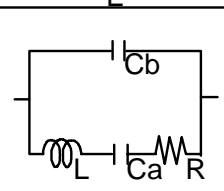
A	B	C
		
D	E	
		
EQV R 38.6347 mΩ EQV L 2.19795 nH	EQV Ca 82.1028 nF EQV Cb F	



Impedance analyzers have more sophisticated models than just parallel or series two-component models. Shown here are five models which can tell you the value of each of the elements in the model. For example, model D (lower-left) is used for capacitors. By taking the capacitor through resonance, the analyzer can determine the value of L, Ca, and R.

This lets us better understand the component and predict its performance in our circuit. These models cover resistors, high and low value inductors, capacitors, and resonators.

RF / Impedance Measurement Basics

Slide #21

Equivalent Circuit Analysis Yields More Accurate Models

Two-Way Tool: Analysis and Simulation

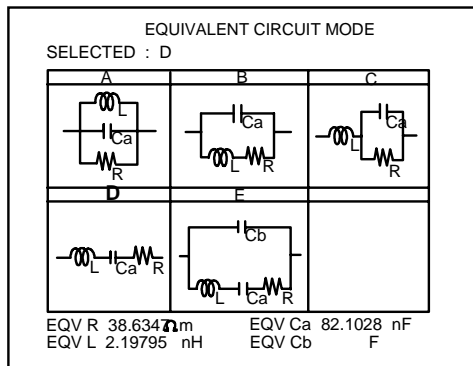

Analysis based on
Measurement Data

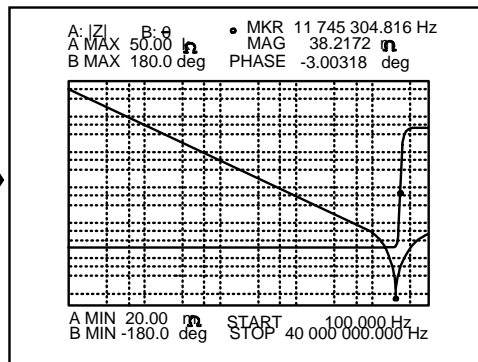

Simulation of equivalent
parameters

The impedance analyzers equivalent circuit function also allows you to modify the values of each of the "sub-components" and simulate the results. This is useful if you know the component will be loaded by another component in the circuit.

RF / Impedance Measurement Basics

Slide #22

Agenda

- Impedance Basics
- ***Measurement Techniques***
- Calibration, Compensation, and Port Extension
- Component Fixturing
- Summary

Now let's review the most common impedance measurement techniques.

RF / Impedance Measurement Basics

Slide #23

Measurement Technique Selection Criteria

- **Frequency**
- **DUT Impedance**
- **Required measurement accuracy**
- **Electrical test conditions**
- **Measurement parameters**
- **Physical characteristics of the DUT**

To simplify the decision process, the following criteria can be used in selecting the most appropriate technique for your application. Remember that some trade-offs might have to be made when selecting the best technique.

RF / Impedance Measurement Basics

Slide #24

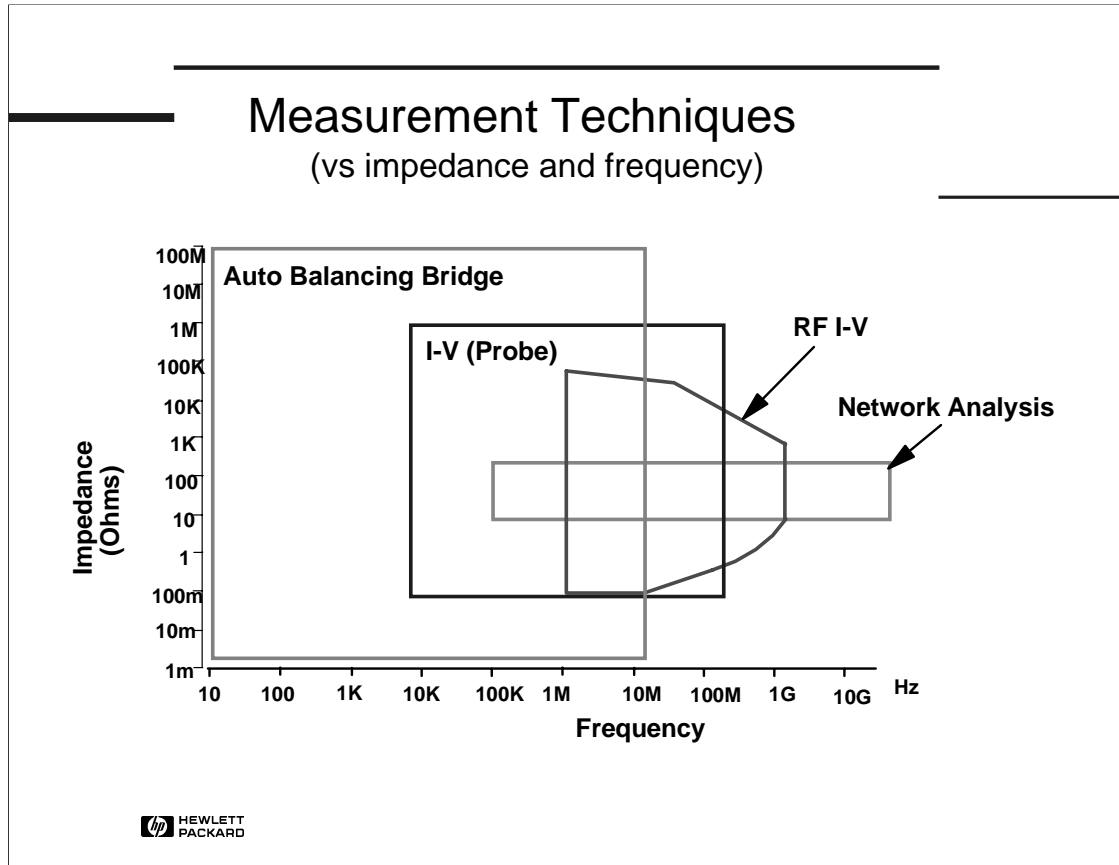

Combining the frequency and DUT impedance criteria into this graph helps visualize the coverage of each technique. The autobalancing bridge provides the widest measurement range with high accuracy. The new RF I-V method is an excellent choice for high frequency impedance measurement. Network analysis covers the highest frequency range, but it is designed to work around 50 Ohms and its impedance range is rather narrow. TDNA and Resonant techniques do not show up, since impedance is not their primary measurement.

RF / Impedance Measurement Basics

Slide #25

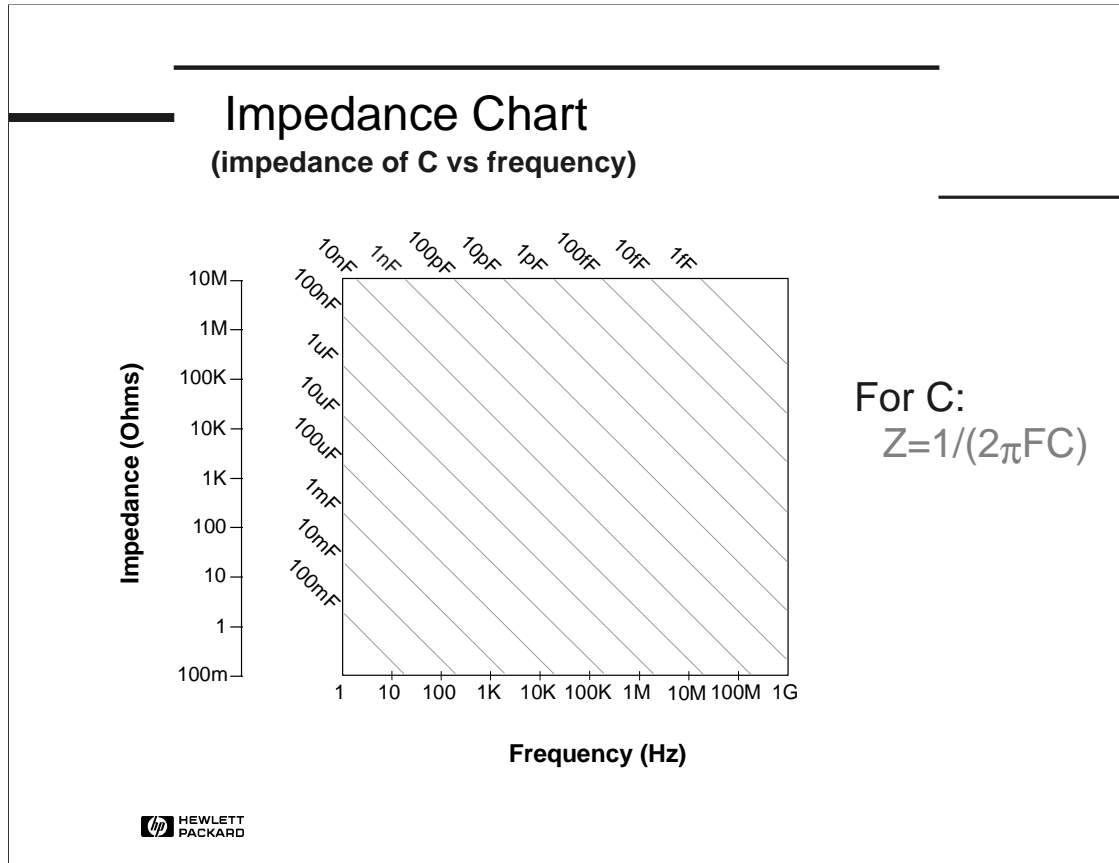

When we are choosing a technique, it is important to understand the approximate value of our DUT. The impedance chart is a simple way to see those values. This is a log-log graph giving the impedance of various perfect capacitors (purely susceptive) versus frequency.

RF / Impedance Measurement Basics

Slide #26

Determining Measurement Accuracy

Find Z value you measure, then see accuracy chart.

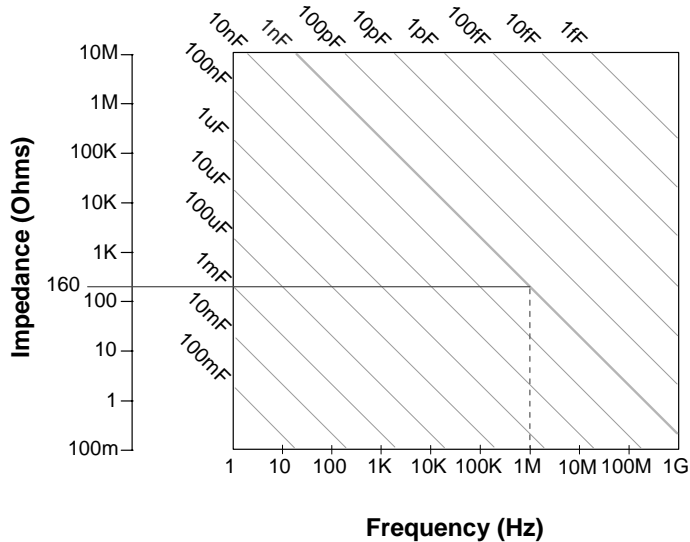

For C:
 $Z=1/(2\pi FC)$

For instance, a 1nF capacitor (bold diagonal) exhibits an impedance of 160 Ohms @ 1 MHz, 160 KOhms @ 1 KHz and 0.16 Ohms at 1 GHz. It is important to realize that impedance varies with frequency. This is why a wide impedance range is critical for making correct impedance measurements. But most components are not only reactive, but also resistive or lossy. Therefore to properly choose the instrument with the appropriate impedance range, we must know the global impedance of the DUT, the resistive part AND the reactive one. Remember, most instruments measure R and X ($Z=R+jX$) and only then calculate Cp or Cs according to the model chosen.

RF / Impedance Measurement Basics

Slide #27

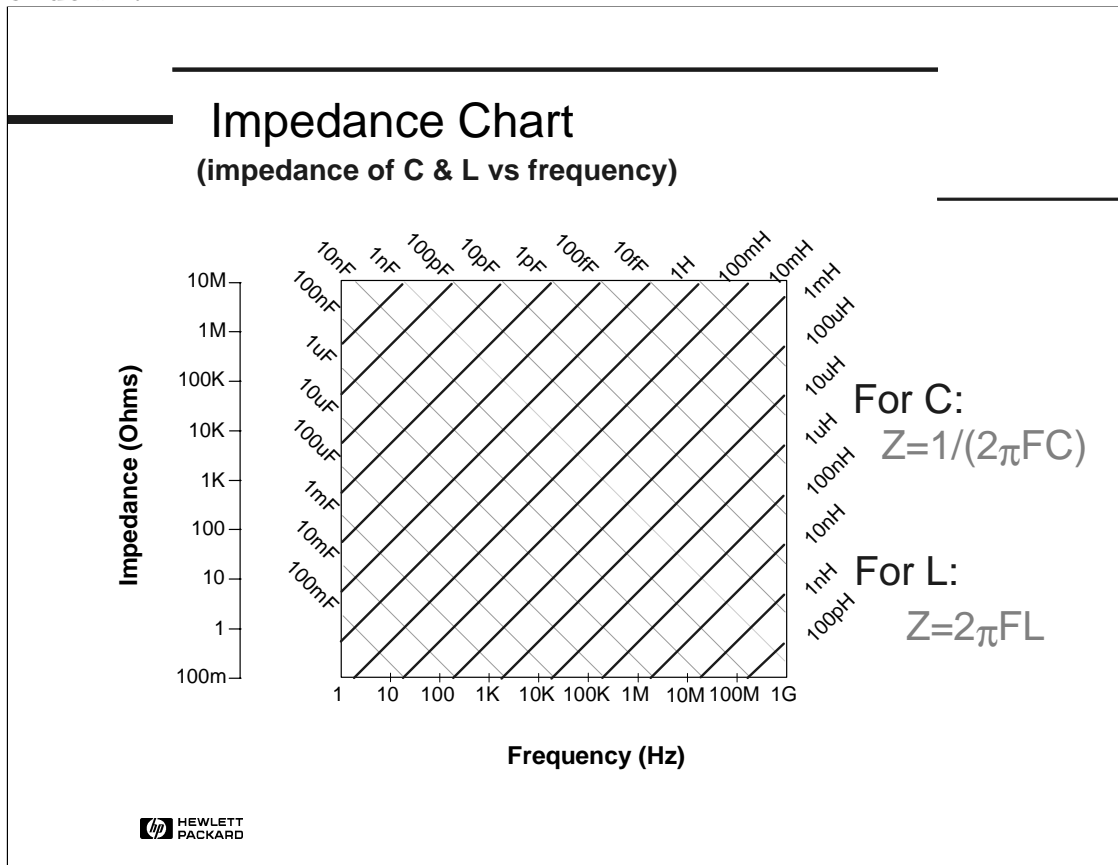

We can fill-out the impedance chart by adding the L values to it as lines perpendicular to the C values.

Slide #28

Auto Balancing Bridge Method
Theory of Operation

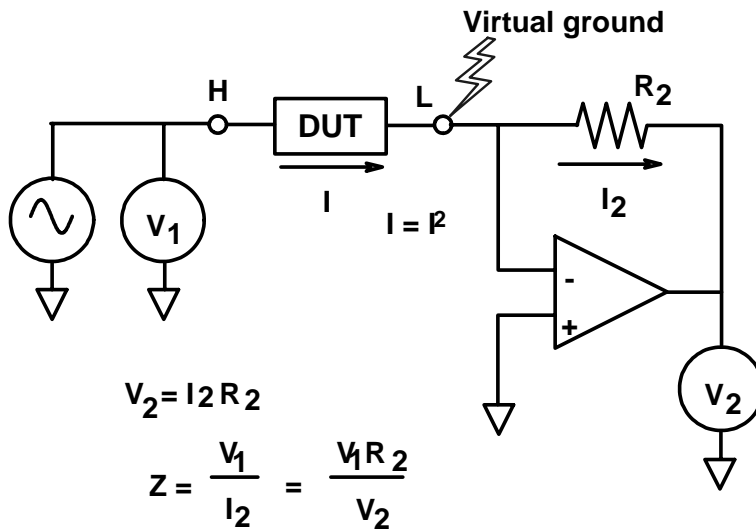

The autobalancing bridge technique essentially measures the voltage across and current through the DUT. Of course, the simplified schematic looks much simpler than it actually is. An important point is that both the voltage and current meters are vector meters (magnitude and phase).

The phase relationship between these 2 meters and the ability of them to accurately separate out the in-phase and quadrature components (especially small real parts in the presence of large reactive values is critical to achieving accurate results).

The autobalancing bridge is by far the best technique for measurements below about 40 Mhz. It provides the most accurate measurements possible and has the widest impedance measurement range. A wide range of AC and DC stimulus can be applied to the component. In addition, because this is a low frequency technique, it is the simplest measurement technique to use. But we often need to go higher in frequency.

RF / Impedance Measurement Basics

Slide #29

High Q Measurements are Difficult

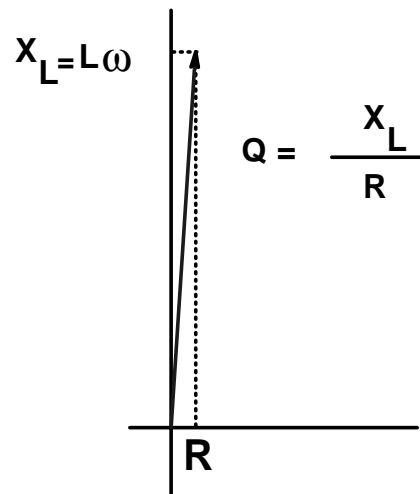

Another limitation of the autobalancing bridge technique is its ability to accurately measure high Q values.

The Q value shown on this slide is about 15. Remember we said Q values can go to over 10,000! Most impedance measurement techniques will have trouble trying to measure Q's of even < 1000 because they have to separate-out the in-phase and quadrature components. But there is one technique which uses a different approach and can give very good measurement results. It's called the resonant technique.

RF / Impedance Measurement Basics

Slide #30

Resonance (Q Meter) Technique Theory of Operation

- Tune C so the circuit resonates
- At resonance $X_D = -X_C$, only R_D remains

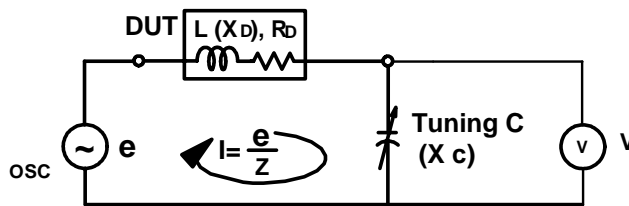

$$X_C = \frac{V}{I} = \frac{R_D V}{e} \quad (\text{at resonance})$$

$$Q = \frac{|X_D|}{R_D} = \frac{|X_C|}{R_D} = \frac{|V|}{e}$$

The resonant technique puts the DUT into a resonant circuit with known components inside the instrument. The instrument source pumps charge into the resonant circuit until it reaches equilibrium. At that point, the Q can be calculated. This technique is the one used by Q-meters so it's sometimes called the Q-meter technique.

Slide #31

Vector Resonance (Q - Adapter)
Theory of Operation

- Automatic tuning
- Transfer function $\bar{H}(\omega)$ yields Q

$$\bar{H}(\omega) = \frac{\bar{V}_H}{\bar{V}_L} = \frac{Q}{Q(1 - \omega^2 LC) + j LC} \quad (\text{at resonance } \omega^2 LC=1)$$

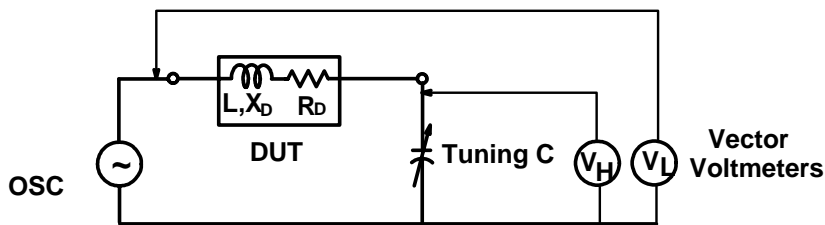

Traditional Q-meters took quite a bit of time to achieve results. They were very manual and required the placement and removal of various components. However, the design of modern automatically tunable air capacitor standards allows fast and very low error measurement of high Q or low D components. In low D capacitor test, it is still difficult to achieve high accuracy measurements due to the need for very stable reference inductors and due to the very low D values that the component may have (<.0001). Testing chip or SMD capacitors requires specific test fixtures which have strays, particularly stray capacitance, which influence the value of the tuning capacitance.

Shown here is the theory of operation of a relatively new technique called vector resonant. This technique provides automated Q measurements and also performs a transfer function which allows test fixture residuals to be removed by compensation and for the measurements to be made rapidly.

Slide #32

New RF I-V Measurement Technique

- **Wide Frequency Range: 1 MHz - 1.8 GHz**
- **Good Accuracy: Basic Accuracy 0.8%**
- **Wide Z Measurement Range: 0.1 - 50 k ohms (at 10% accuracy)**
- **Employed by:**
 - HP 4291B (1 MHz - 1.8 GHz)
 - HP 4286A (1 MHz - 1 GHz)

Also new is the measurement technique called RF I-V. It achieves more accurate measurements over a broader impedance range than the traditional reflection (Network Analyzer) technique which has historically been used at higher frequencies. At this time, the RF I-V technique is limited to 1.8 GHz.

RF / Impedance Measurement Basics

Slide #33

RF I-V Technique Theory of Operation

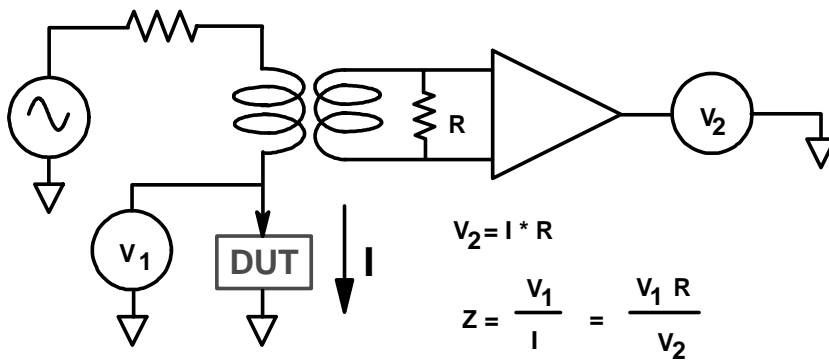

In the simplified schematic form, the RF I-V technique is quite straight forward. We have a source which provides the stimulus across the DUT. The voltage across the DUT is directly measured and the current through the DUT is coupled with a current transformer and then goes to a current-to-voltage converter which then goes to another voltmeter. Again both of these voltmeters are vector voltmeters. Although this is a 50 Ohm system, the technique has a very good impedance measurement range with quite good accuracy.

RF / Impedance Measurement Basics

Slide #34

RF I-V Technique Theory of Operation

High Impedance Test Head

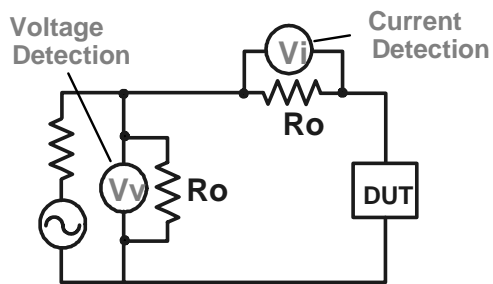

Low Impedance Test Head

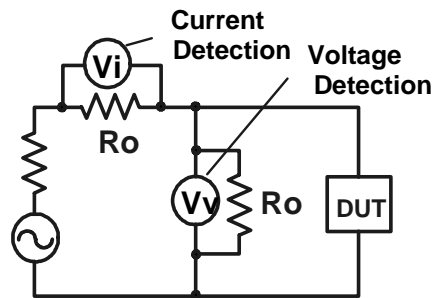

Since high frequency, high accuracy measurements are tough, we need all of the help that we can get. To help us a little more, there are 2 test heads; one that is optimized for higher impedances and one optimized for lower impedances. Choosing one test head over the other will change your impedance range-of-coverage by about 1 order of magnitude.

RF / Impedance Measurement Basics

Slide #35

Network Analysis Method Theory of Operation

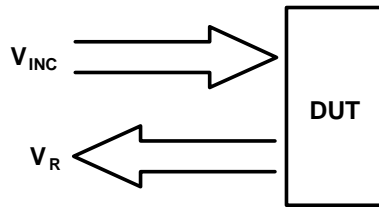

$$\Gamma = \frac{V_R}{V_{INC}} = \frac{Z_L - Z_0}{Z_L + Z_0}$$

The Network Analysis method measures the reflection from the DUT of an incident wave. This is normally done using a directional coupler in a T-R or S-parameter test set.

RF / Impedance Measurement Basics

Slide #36

Network Analysis Example Waveforms

Example V_{INC} and V_R

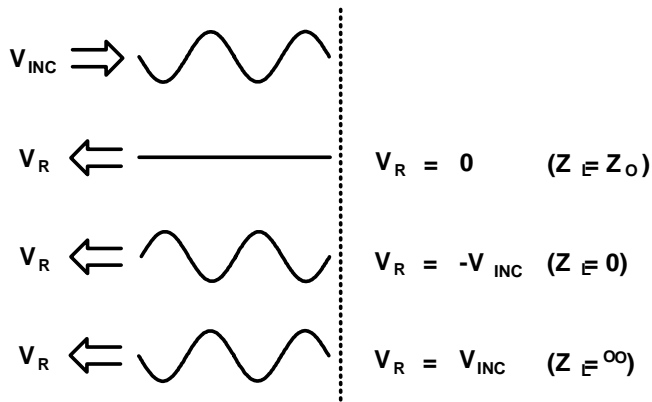

To review the concept of reflection of mismatched impedances, we can look at the boundary conditions for some DUT impedances. Of course, practical DUT's will have more complicated reflections.

RF / Impedance Measurement Basics

Slide #37

RF I-V Method vs. Reflection Method

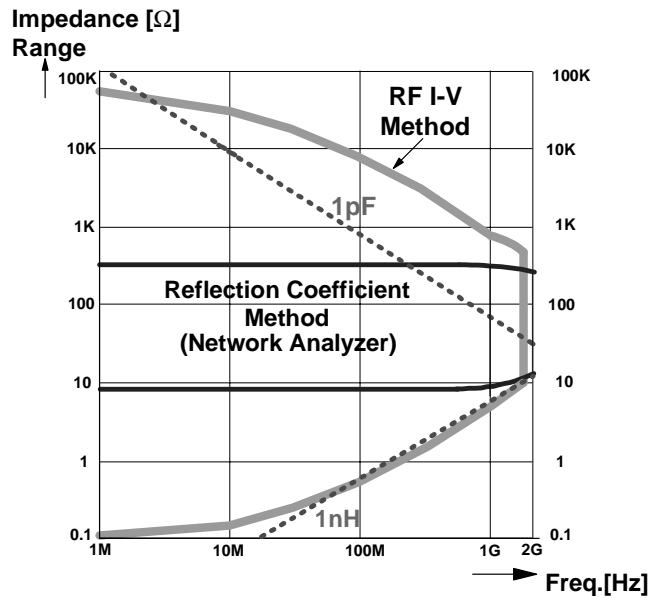

The reflection technique provides very good accuracy if the DUT's impedance is near 50 Ohms, but it falls-off rapidly as we move away from that central impedance. This graph shows the expanded range that can be covered by the RF I-V technique.

In historical high frequency communication systems components often operated near 50 or 75 ohms, but today's systems require operation over a broader range of conditions and frequencies so we can see more components operating away from 50 or 75 ohms. Also, in the measurement of materials (e.g. dielectric materials) we can not expect the impedance range to be anywhere near 50 Ohms.

RF / Impedance Measurement Basics

Slide #38

TDR Theory of Operation

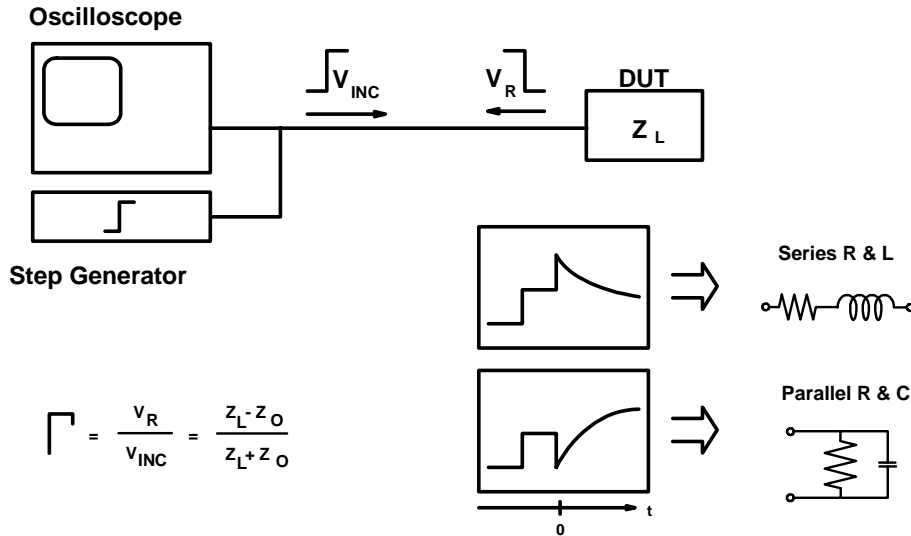

$$\Gamma = \frac{V_R}{V_{INC}} = \frac{Z_L - Z_0}{Z_L + Z_0}$$

Time Domain Reflectometry also relies on the principle of DUT's reflecting waves. But in this case, it is not looked at in the frequency domain but in the time domain. Looking in the time domain lets us understand the characteristics of "DUTs" like fixtures, PC board traces, cables, etc where we want to find distributed characteristics and discontinuities.

RF / Impedance Measurement Basics

Slide #39

Simple Selection Rule Summary

- **Auto balancing bridge,
low frequency, $f < 40\text{MHz}$**
- **RF I-V, high frequency impedance measurement,
 $1\text{MHz} < f < 1.8\text{GHz}$**
- **Network analysis,
high frequency, $f > 1.8\text{GHz}$**
- **Resonant, high Q and low D**
- **TDNA, discontinuities and distributed
characteristics**



Here we attempt to provide a simple summary for best technique selection. Usually frequency is the first decision factor to use when choosing a measurement technique. Then consider the other criteria:

- * DUT impedance
- * Required measurement accuracy
- * Electrical test conditions
- * Measurement parameters
- * Physical characteristics of the DUT

Often the DUT's impedance range is completely ignored, which leads to big discrepancies with the measurement result expectations.

RF / Impedance Measurement Basics

Slide #40

Measurement Methods and HP products (1)

Measurement Method	HP Products	Frequency range
Auto Balancing Bridge (Four-Terminal Pair)	HP 4263B LCR Meter	100Hz to 100 kHz spot
	HP 427xA LCR Meters	100Hz to 10MHz spot
	HP 4284A Precision LCR Meter	20Hz to 1MHz spot
	HP 4285A Precision LCR Meter	75KHz to 30MHz
	HP 4192A LF Impedance Analyzer	5Hz to 13MHz
Resonant (Q-Meter)	HP 4194A Impedance/Gain-Phase Analyzer	10Hz to 40MHz
	HP 42851A Q Adapter (with HP 4285A)	75KHz to 30 MHz
I-V (Probe)	HP 41941A Impedance Probe (withHP 4194A)	10KHz to 100MHz
	HP E4916A Crystal Impedance/LCR Meter (with Opt.010)	1MHz to 180MHz
RF I-V	HP 4286A RF LCR Meter	1 MHz to 1 GHz
	HP 4291B Impedance/Material Analyzer	1 MHz to 1.8 GHz

This table gives a listing of different Hewlett-Packard products and the techniques that they use. Selecting the proper instrument for a specific measurement may not be a trivial task. As we have been discussing, many parameters need to be considered to make the correct choice.

RF / Impedance Measurement Basics

Slide #41

Measurement Methods and HP products

Measurement Method	HP Products	Frequency range
Network Analysis (Reflection Coefficient)	HP 4395A Network/Spectrum Analyzer with HP 43961A Impedance Test Set	100 kHz to 500MHz
	HP 4396B Network/Spectrum Analyzer with HP 43961A Impedance Test Kit	100 kHz to 1.8 GHz
	HP 8751A Network Analyzer	5Hz to 500MHz
	HP E5100A/B Network Analyzer	10kHz to 300MHz
	HP 8752C/8753E RF Network Analyzers	300KHz to 1.3GHz/6GHz
	HP 8510 Network Analyzer	45 MHz to 100GHz
	HP 8719C/8720C Network Analyzers	130MHz to 13.5GHz/20GHz

RF / Impedance Measurement Basics

Slide #42

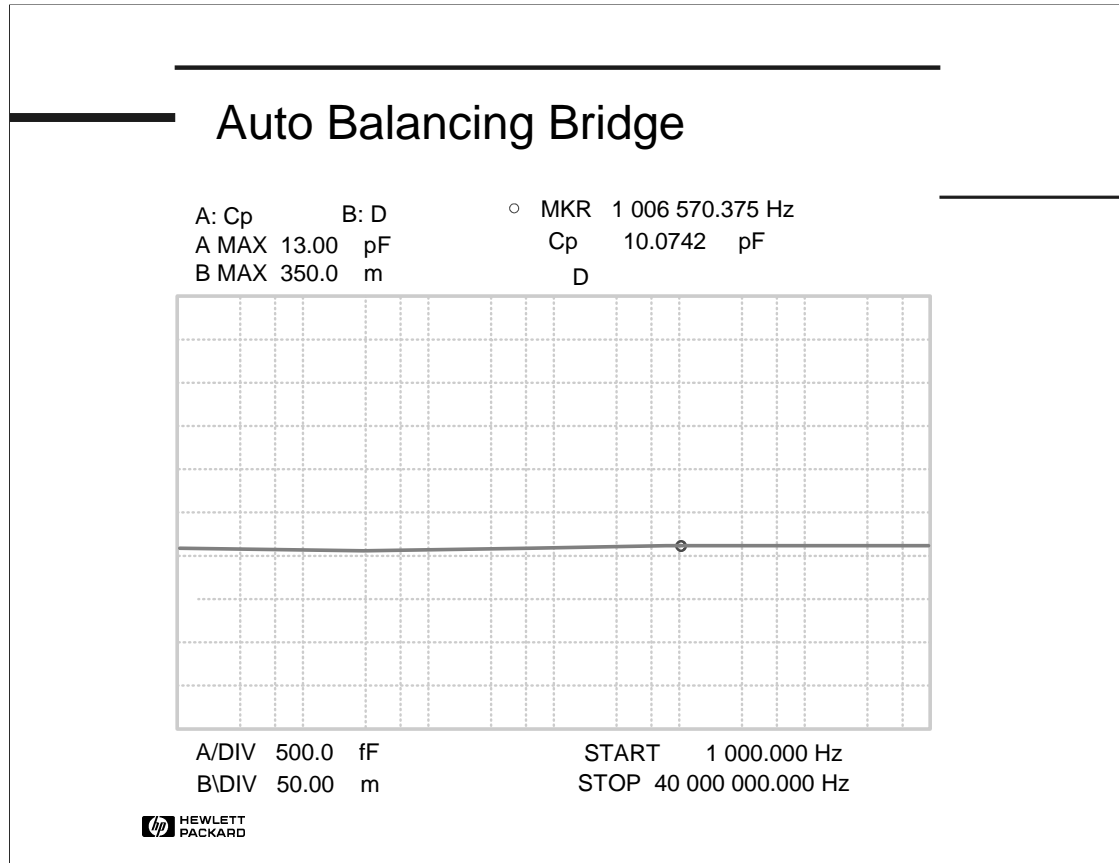

This measurement has been made with the HP 4194A Impedance Analyzer which is an autobalancing bridge. From 1 MHz to 40 MHz, the measurement was very stable and shows the parallel capacitance with very high resolution. The variation on the full frequency range is less than 100 fF! There are some fluctuations in the lower end because of the higher impedance of the capacitor.

RF / Impedance Measurement Basics

Slide #43

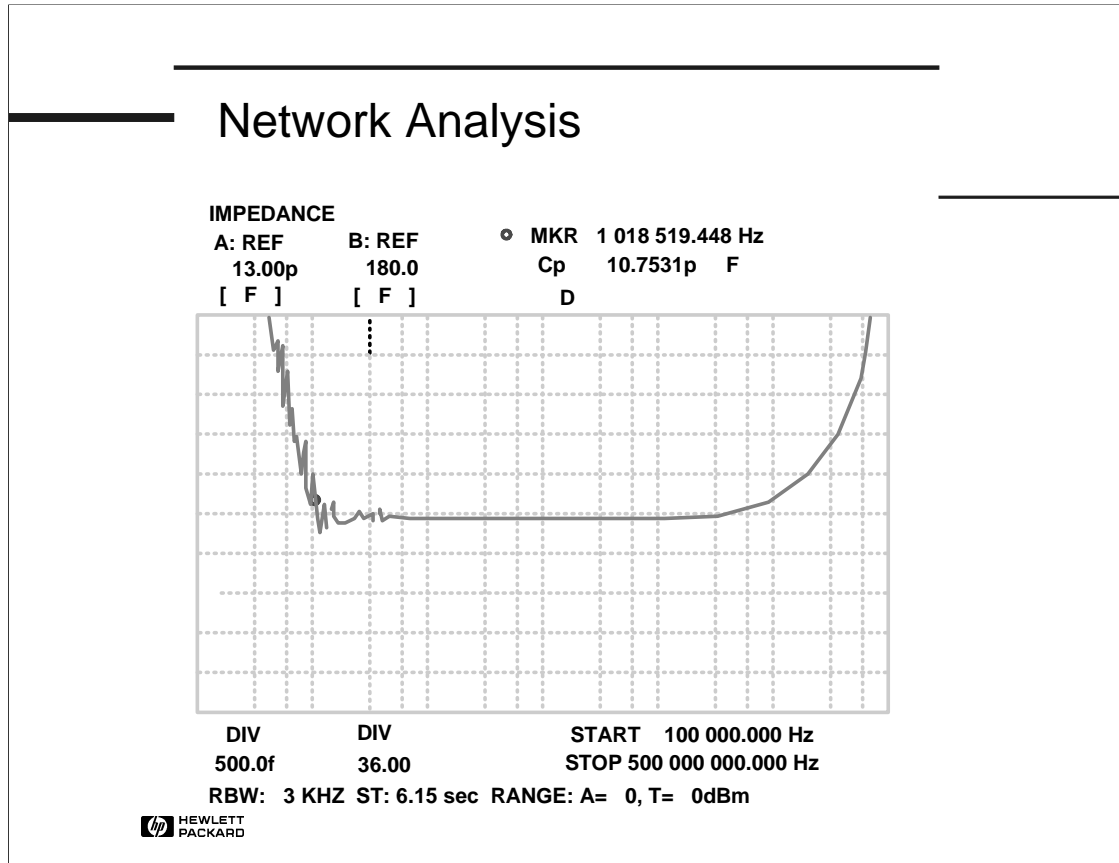

This measurement has been done on a 500 MHz Network Analyzer. In the low frequencies, the impedance of the capacitor is far enough from the 50 Ohm system impedance to very clearly demonstrate the impedance range limitation of this technique. Closer to 50 Ohms, the results are similar to the ones given by the other techniques. In the higher frequencies, we start to see the resonant frequency. Actually this instrument does not go high enough in frequency to visualize the resonance point, but at least gives some useful information (further analysis would need to be done using a higher frequency instrument.)

RF / Impedance Measurement Basics

Slide #44

Agenda

- Impedance Basics
- Measurement Techniques
- ***Calibration, Compensation, and Port Extension***
- Component Fixturing
- Summary

Next we will discuss the topics of calibration, compensation, and port extension. These are critical topics to achieve accurate measurements at RF frequencies.

RF / Impedance Measurement Basics

Slide #45

What is Calibration ?

- To define the "Calibration Plane" at which measurement accuracy is specified and traceable

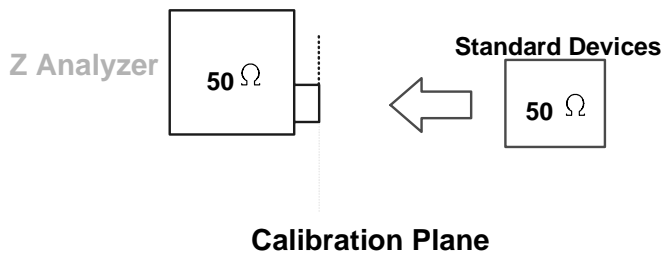

First we need to understand that Compensation is different than Calibration. Let's start by defining Calibration.

Calibration is to define a reference plane where the measurement accuracy is known, specified, and traceable to national laboratories. This plane is called the Calibration Plane. The calibration plane is usually at the UNKNOWN terminals of our measuring instrument. On an autobalancing bridge product, these terminals are on the front panel as 4 BNC terminals. For a RF I-V or network analyzer instrument, the terminals are located at the test set.

Another difference is who sets the calibration. For example the calibration of autobalancing bridges is done at the factory when they are produced and is updated with regular (e.g. yearly) calibration. For the higher frequency techniques, it is too difficult to make instruments which can hold their calibration over time and different set-ups (connector variations, etc.). In those cases Calibration is actually done by the user normally through the three standards: 0 Ohms, 0 Siemens, and 50 Ohm loads. The user is actually doing the calibration using traceable standards.

RF / Impedance Measurement Basics

Slide #46

Definition of Compensation

To reduce the effects of error sources existing between the DUT and the instrument's "Calibration Plane".

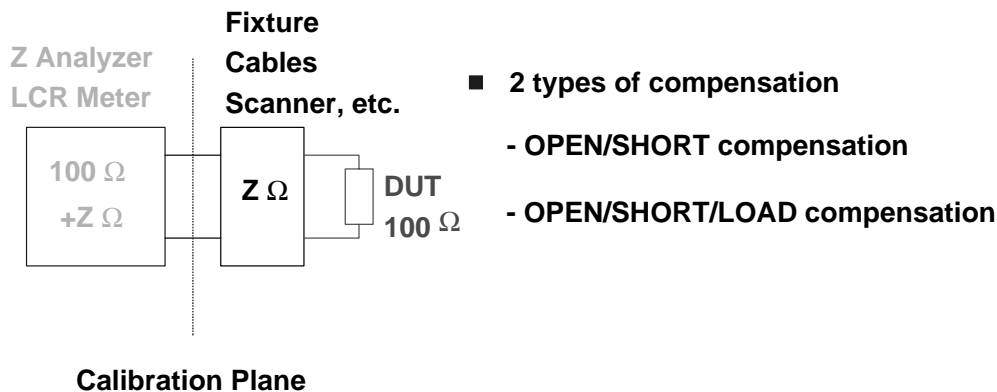

"Compensation" reduces the measurement error induced by test fixtures between the DUT and the calibration plane. When a Device Under Test (DUT) is directly connected to the calibration plane, the instrument can measure it within the specified measurement accuracy. However, test fixtures are usually connected between the calibration plane and the DUT in actual measurements, and they degrade the total measurement accuracy by their residuals. There are two types of compensation techniques that need to be discussed, OPEN/SHORT and OPEN/SHORT/LOAD.

RF / Impedance Measurement Basics

Slide #47

Open / Short Compensation

- Residual Impedance Error Eliminated

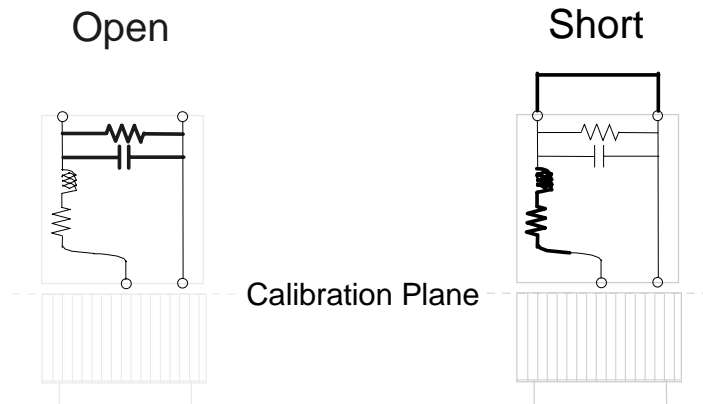

OPEN/SHORT compensation is the most popular compensation technique. In OPEN/SHORT compensation, the residuals of a test fixture can be modeled as an equivalent circuit. Since $Z_s \ll 1/Y_o$, stray admittance Y_o can be measured when the test terminals are open. Residual impedance Z_s can be measured when the test terminals are shorted. Then the DUT measurement data Z_m is compensated by the calculation using OPEN and SHORT measurement data, then the true value Z_{dut} can be obtained. Note that each parameter has real and imaginary components.

RF / Impedance Measurement Basics

Slide #48

Compensation Concept

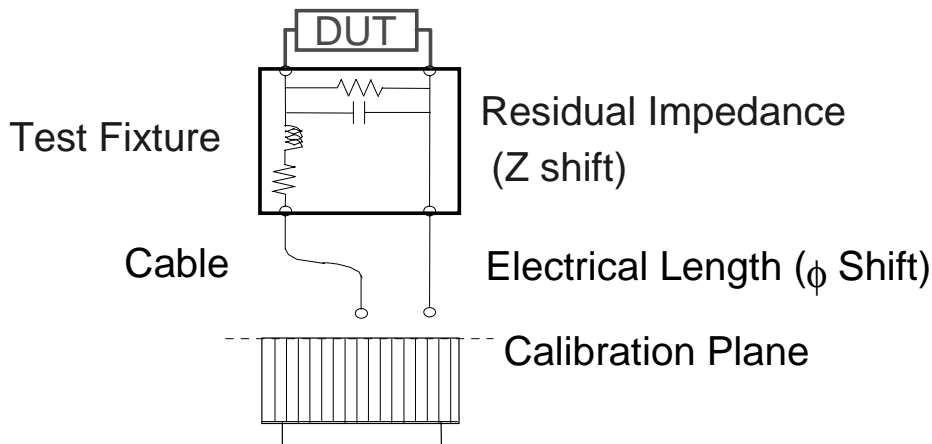

Simple Open and Short compensation do have limits. The biggest is they do not consider the electrical length of the fixture (or connection path) which will cause phase shift. As we know, phase shift is very critical to our Q and D value accuracy. There may also be other complicated strays in our fixturing.

At lower frequencies, these affects may not be so large, but at higher frequencies, their affects are almost certain to create errors. Even millimeters of uncompensated electrical length will create measurement problems at 1 GHz.

Slide #49

OPEN/SHORT/LOAD Compensation

- Basic Theory -

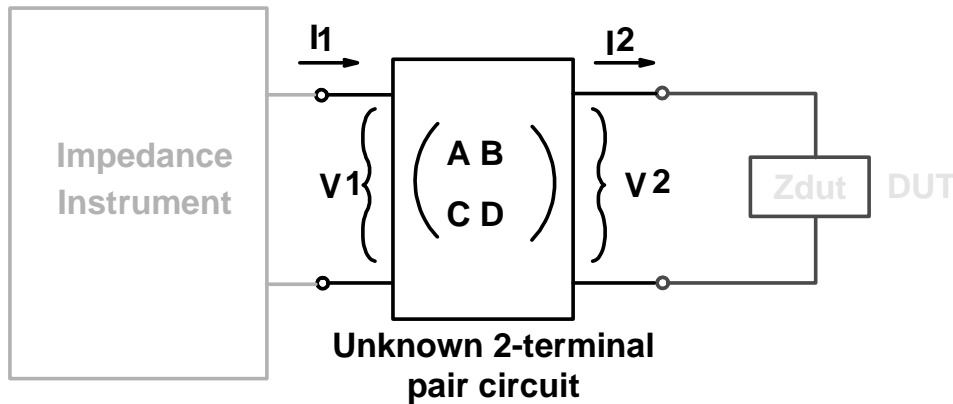

OPEN/SHORT/LOAD compensation requires the measurement data of a standard device with a known impedance value in addition to the OPEN/SHORT measurement data. The residuals of a test fixture are defined as a four-terminal network expressed with A, B, C, D parameters. Assuming that the impedance measurement value of a DUT with a true value Z_1 becomes Z_2 at the test terminals, the following equation can be derived.

$$Z_1 = (A \cdot V_2 + B \cdot I_2) / (C \cdot V_2 + D \cdot I_2)$$

$$= (A \cdot Z_2 + B) / (C \cdot Z_2 + D)$$

where $Z_1 = V_1/I_1$ and $Z_2 = V_2/I_2$

Slide #50

OPEN/SHORT/LOAD Compensation

- **Eliminates complicated residuals**
- **Eliminates phase shift error**
- **Maximizes correlation between instruments**

OPEN/SHORT/LOAD compensation is effective to solve problems which cannot be corrected with OPEN/SHORT compensation.

RF / Impedance Measurement Basics

Slide #51

Advanced Compensation in 4291B

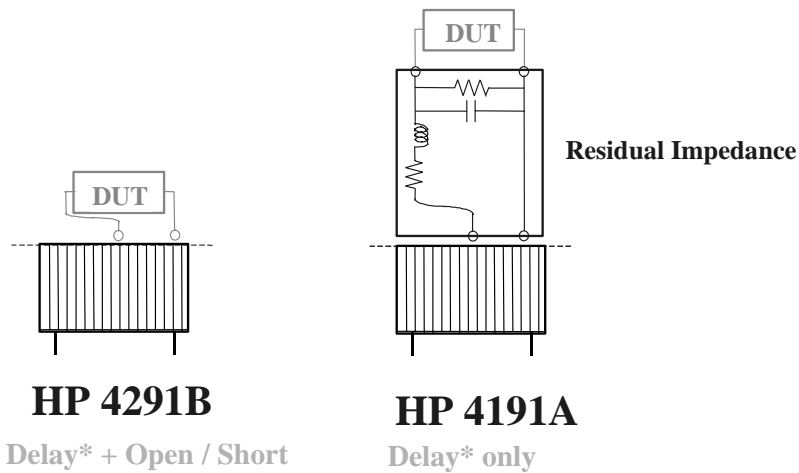

*Delay = Port Extension

Network analyzers and older impedance analyzers (like the HP 4191A) do not contain compensation correction. They only have port extension. This means that the DUT is being measured with the residual impedance. That limits our ability to see the real component performance.

RF / Impedance Measurement Basics

Slide #52

Measurement Example Using Different Compensations

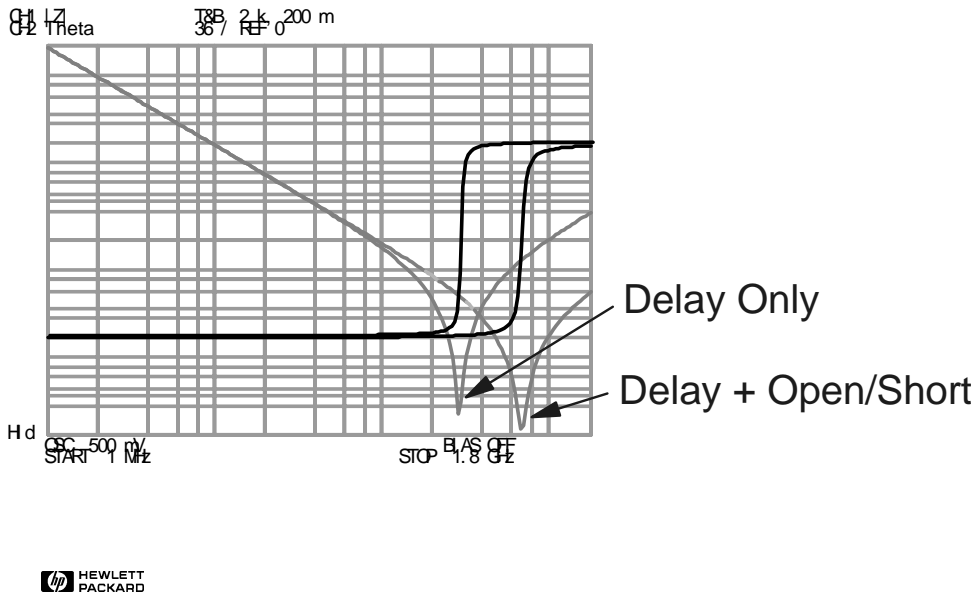

This is an example measurement of a capacitor made with and without compensation functions.

RF / Impedance Measurement Basics

Slide #53

High Q Measurements at High Frequencies are Particularly Difficult

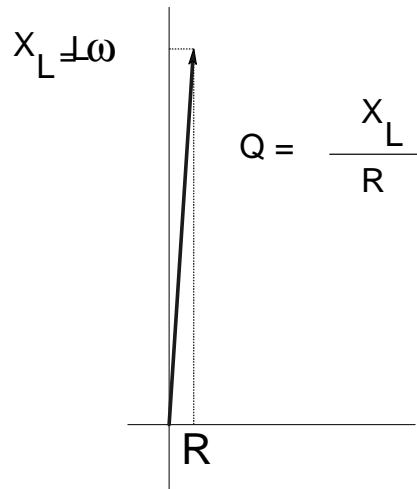

As we've already talked about high Q measurements are very difficult. They are even more difficult at high frequencies.

RF / Impedance Measurement Basics

Slide #54

New Technique to Measure High Q
at High Frequencies

Available in HP4291B/4286A

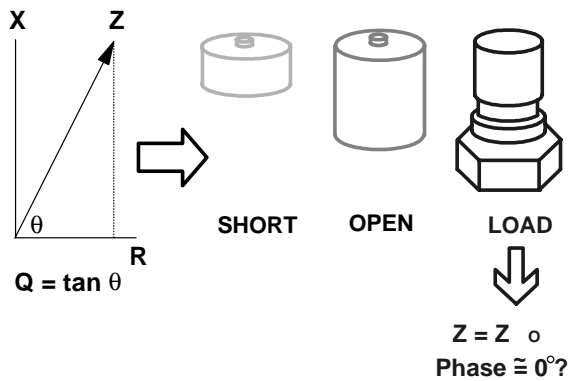

Phase angle references are very important to get good measurement results. These references are set by the user when calibration is performed. The main issue is the 50 Ohm load. It is almost purely resistive, but not quite. That small degree of phase shift error makes a problem for us.

RF / Impedance Measurement Basics

Slide #55

New Technique to Measure High Q at High Frequencies

Available in HP4291B/4286A

X

Z

θ

R

$Q = \tan \theta$

SHORT OPEN LOAD

↓

$Z = Z_o$
Phase ≈ 0 ?

+

Air (low loss)
Capacitor

$Z = \frac{1}{j\omega C}$

Phase = -90

hp HEWLETT
PACKARD

RF | Impedance Measurement Basics GA imped98.ppt

10-98
55

To improve our results, the HP 4291B and 4286A use an additional error correction term for their calibration. This is a low loss capacitor. Actually, we don't care about the C value of this capacitor, but only its phase angle. It is an almost perfect -90°. This lets us fine tune the coordinates making a huge difference in specified Q accuracy.

RF / Impedance Measurement Basics

Slide #56

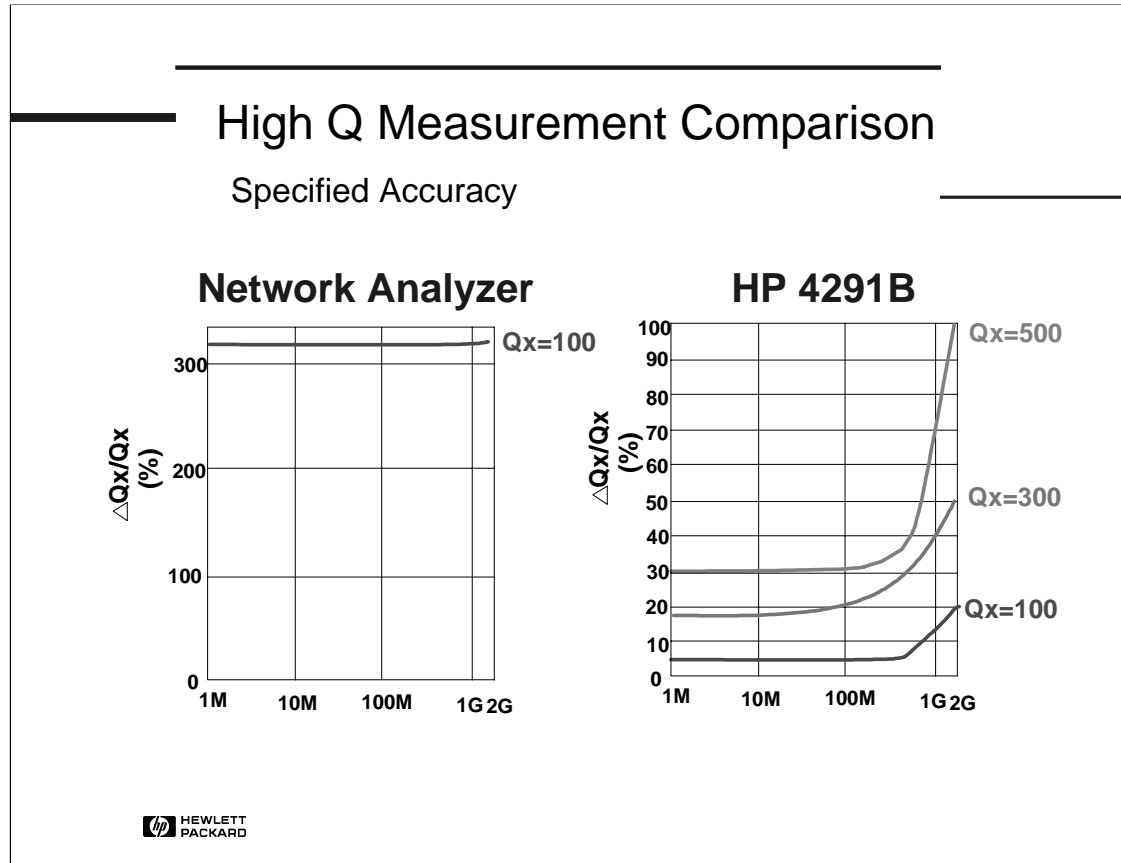

Here we can see the specified accuracy with and without the special calibration technique. The HP 4291A is also better due to its more accurate RF I-V measurement technique, but the main improvement comes from the additional calibration term.

Typical measurements may have better results than these specified accuracies, but for Q's over 100, the reflection technique without special calibration is not likely to give useable results.

RF / Impedance Measurement Basics

Slide #57

How Accurate is the New Calibration Method?

- **Compare with HP 42851A Precision Q Adapter**
 - **Widely Used (Industry Standard)**
 - **High Q Measurement Accuracy**
 - **75 kHz - 30 MHz**

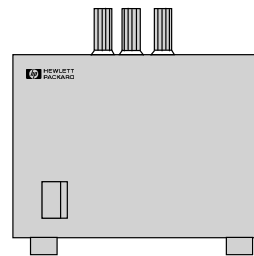

HP 42851A

To verify that our new technique improves results, we took a sample component and measured it using both the RF I-V with special calibration and the vector resonant technique (which has a different technique for achieving high accuracy Q measurements).

RF / Impedance Measurement Basics

Slide #58

Good Data Correlation

- HP 4291B vs. HP 42851A -

Freq. [MHz]	HP 4291A	HP42851A	Delta [%]
1	225.4	235.8	-4.4
2.5	164.8	176.8	-6.8
4	220.5	230.1	-4.2
7.9	221.9	235.7	-5.9
10	235.8	251.2	-6.1
25	233.3	254.8	-8.4
30	232.2	263.0	-11.7

These are the results from our experiment. We can see good correlation between the measurement techniques. The results are still not in perfect correlation, but we know Q measurements are very sensitive and even removing, re-inserting, and re-measuring the same component will give many percent of deviation.

RF / Impedance Measurement Basics

Slide #59

Agenda

- Impedance Basics
- Measurement Techniques
- Calibration, Compensation, and Port Extension
- *Component Fixturing*
- Summary

Our last major topic to be discussed is component fixturing.

RF / Impedance Measurement Basics

Slide #60

SMD and Material Test Fixtures a critical need for good results

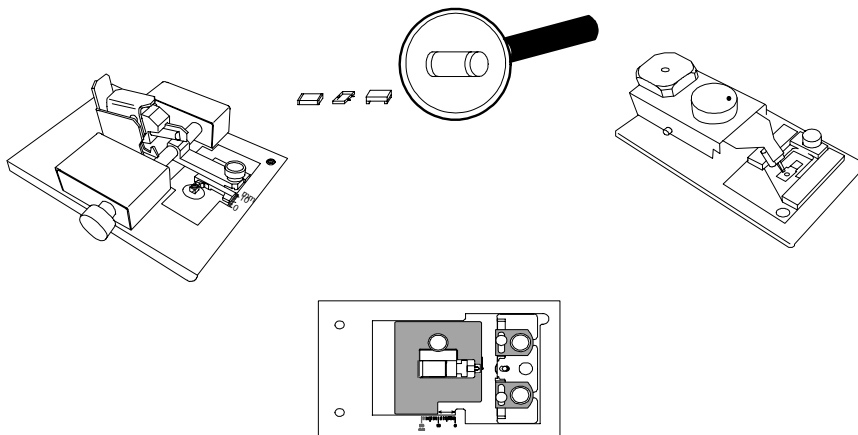

When we are trying to measure SMD components or dielectric or magnetic materials, fixturing becomes one of our most important issues. As we know, calibration of our RF instruments leaves us with an APC-7 (or other) industry standard connector. But the components and materials have very different geometries!

Whether you are the user of "standard" HP fixtures or need to design your own, some topics need to be understood to achieve accurate results. Let's look at some of those.

Slide #61

SMD Fixture Compensation

- **OPEN Compensation**
 - Same Distance
- **SHORT Compensation**
 - Same-size Shorting Device
 - 16191A/2A/3A/4A furnishes
 - (1 x 1 x 2.4 mm)
 - (1.6 x 2.4 x 2 mm)
 - (2.4 x 2.4 x 3.2 mm)
 - (2.4 x 2.4 x 4.5 mm)

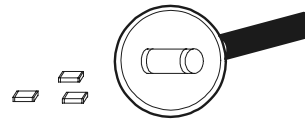

Of course OPEN and SHORT compensation are important. Most important for the OPEN is that the contacts be in approximately the same position that they will be in when the component is inserted. The SHORT is the tougher of the two. To help get a good short compensation, we supply gold plated low resistance/low inductance shorting blocks with our fixtures, that are similar geometries to common SMD components. If you do not have a good short, it may be better to avoid do that compensation than doing a bad compensation. It is easy to do a bad short compensation; usually the problem is not the resistance but the inductance.

Electrical length compensation is also important. With the HP RF I-V instruments and fixtures, you can choose the fixture model number from a softkey menu. Then the instrument will automatically compensate for some of the fixture parasitics including port extension (i.e. delay).

RF / Impedance Measurement Basics

Slide #62

SMD Fixture Requirements

- **Good Contact**
 - Stable & High Pressure
 - Low R material
- **Point Contact**

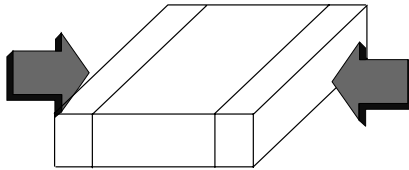

Fixture contacts should have an appropriate and repeatable pressure. You prefer a point contact and the contact material should be durable and low resistance. Gold is a good contact material due to its low resistance and lack of oxidation, but unfortunately, it is not the most durable.

RF / Impedance Measurement Basics

Slide #63

SMD Fixture Requirements

Accurate Positioning of DUT

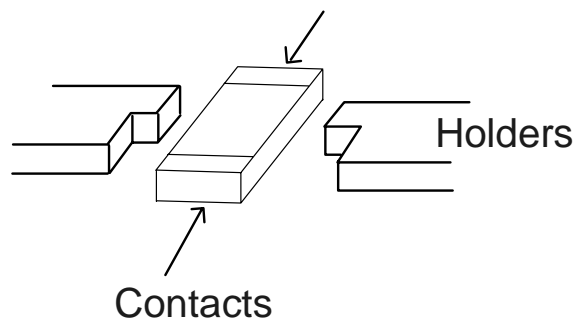

The position of the DUT is very important to achieve repeatable results. Side holders or guides are one aid here.

RF / Impedance Measurement Basics

Slide #64

Measurement Example Using Different DUT Positioning

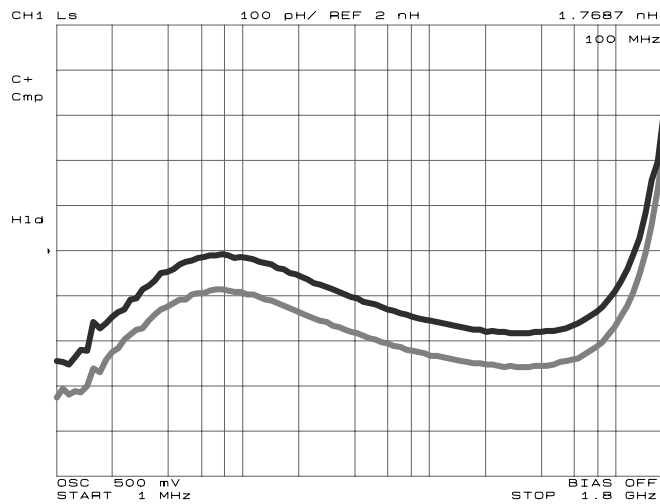

DUT: 2 nH

Position:
0.3 mm difference

This slide shows the measurement of a 2nH inductor with a very slight difference in position.

Slide #65

New RF Component Precision Fixtures

- **For new smallest SMD devices:**
 - **0603 EIA, 1608 mm**
 - **0402 EIA, 1005 mm**
- **Improved measurement repeatability due to standardized component positioning**

Component positioning issues have become much more important as the components are becoming very small. For that reason, HP will soon introduce a new set of fixtures focused on these small devices. They eliminate the positioning variance that we experienced with the prior fixtures. These should be available near the end of 1998.

RF / Impedance Measurement Basics

Slide #66

New RF Component Precision Fixtures

HP16196A/B SMD Test Fixtures

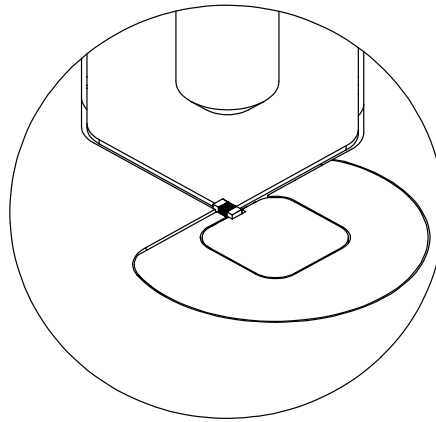
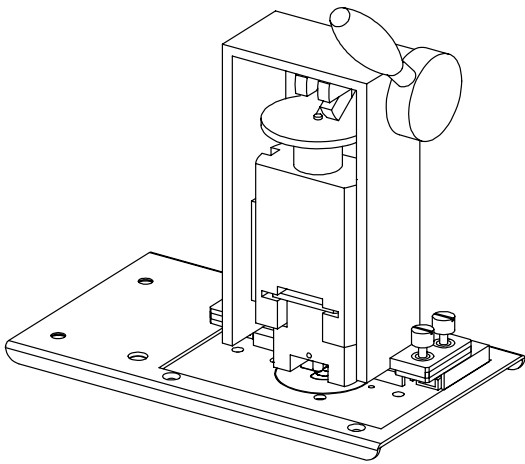

RF / Impedance Measurement Basics

Slide #67

Fixtures Need to Support Wide Level Coverage (AC & DC)

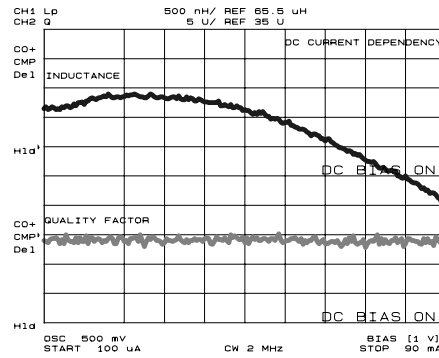
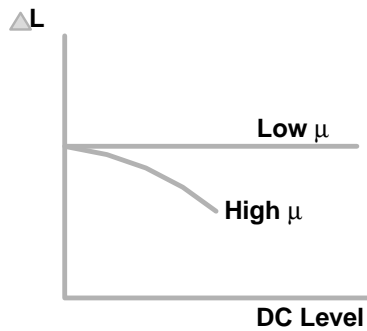

At the beginning of this paper we discussed the parasitics due to signal amplitude. This means we need fixtures that will support those higher voltages and higher currents.

RF / Impedance Measurement Basics

Slide #68

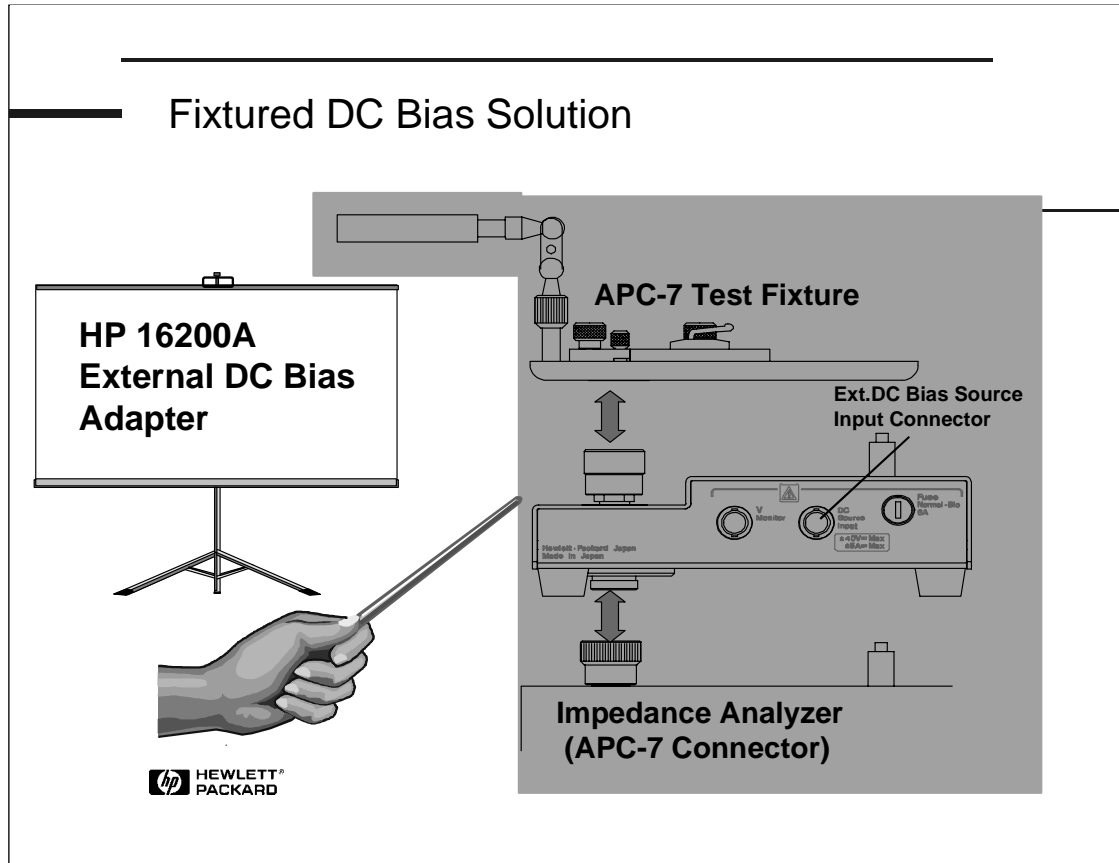

HP has also introduced a DC bias adapter which sits on top of the RF I-V test sets. It replicates this plane, so all of the standard fixtures can sit directly on top of it.

RF / Impedance Measurement Basics

Slide #69

Measurement Example Using the HP 4291B with HP 16200A

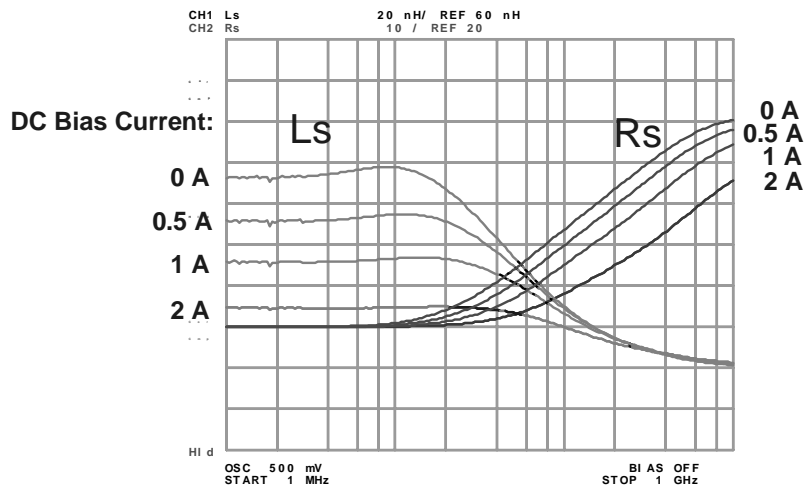

This shows how convenient it is to make measurements and the variation that we expect from an inductor.

Slide #70

Special Compensation Aids for DC Bias Adapter

OPEN/SHORT/LOAD
for 4291B+16200A+Fixture

16200A furnishes

- Shorting Device (4ea.)
- Load Device (51ohm, 4ea.)
 - 1mm x 0.5mm
 - 1.6mm x 0.8mm
 - 2.0mm x 1.25mm
 - 3.2mm x 1.6mm

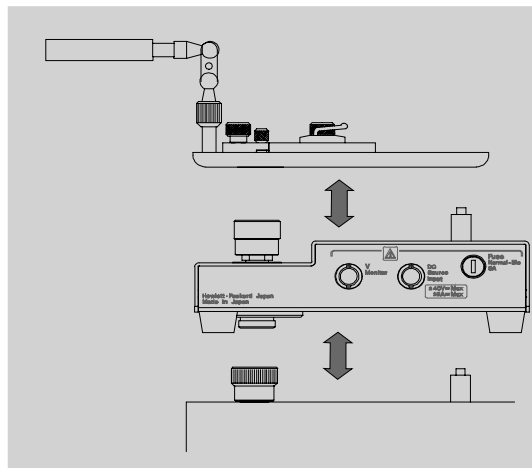

When using this fixture we again need to do compensation. To assist with that we provide some additional shorting and load devices to do load compensation and remove the additional affects from the DC bias adapter.

Slide #71

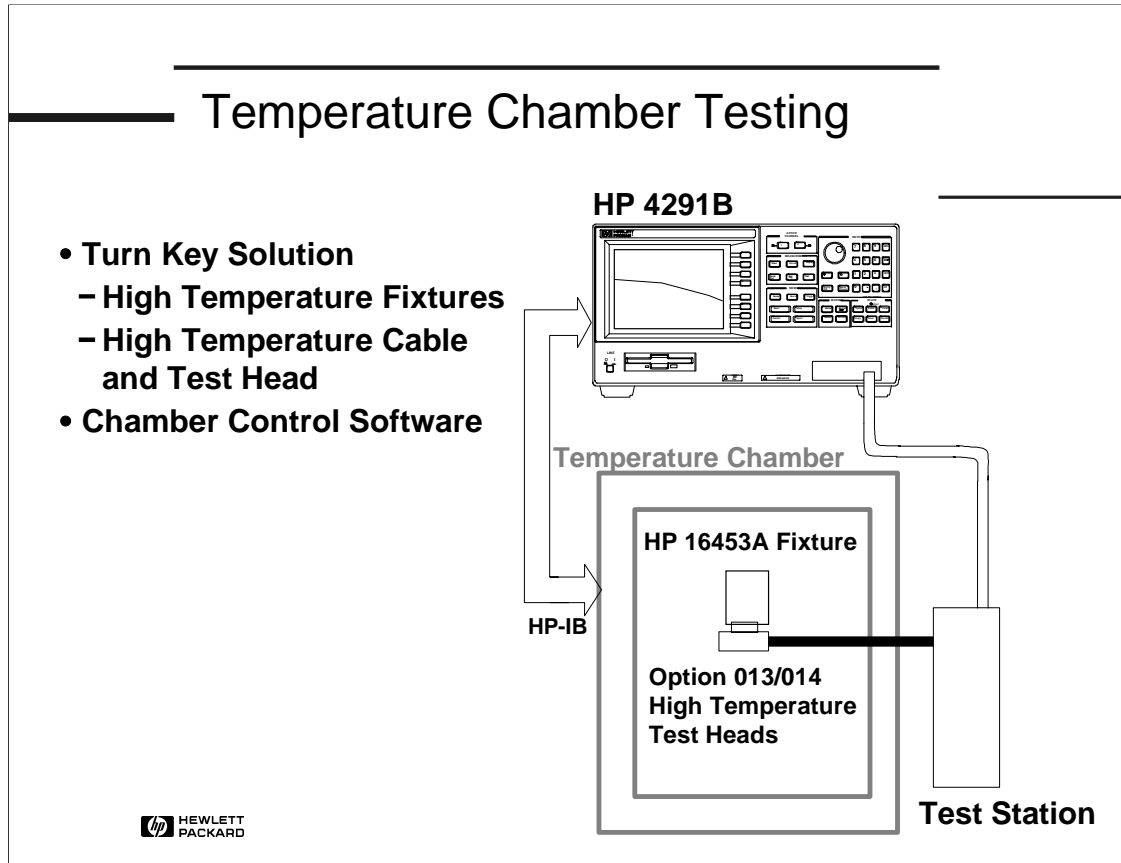

The last need that we will discuss for fixtures is the need to do evaluation in temperature chambers. The HP 4291B has test heads that move the measurement (calibration plane) into the oven (up to 200° C). Also available are special fixtures designed as well to operate in those environments. These fixtures have special spring-loaded contacts to avoid putting excessive or too little pressure on the components as they expand and contract. Software is available which lets the 4291B control the temperature chamber without the use of a PC or other controller.

RF / Impedance Measurement Basics

Slide #72

Agenda

- Impedance Basics
- Measurement Techniques
- Calibration, Compensation, and Port Extension
- Component Fixturing
- *Summary*

Slide #73

Summary

- **RF Impedance Measurements are Challenging**
- **Use Equivalent Circuit Analysis and Models if Possible or Understand Limits of Other Models**
- **Choose Best Measurement Technique**
- **Calibration, Compensation, and Port Extension are Critical; They Must Be Understood and Performed Correctly**
- **Custom Fixture Designers Need to Consider Many Factors**

Thank you for attending our seminar. We hope you have learned some information that will help you achieve better RF component measurement results.

Slide #74

Making Quality RF Impedance Measurements



Back to Basics Seminar

RF / Impedance Measurement Basics

Slide #75

Appendix

Back to Basics Seminar

Slide #76

Key Literature

- **Impedance Analyzer / LCR Meter Selection Guide (P/N 5952-1430E)**
- **Impedance Measurement Handbook (PN 5950-3000)**
[soon to be available on www.hp.com]
- **Accessories Guide for Impedance Measurements (PN 5963-6834E)**

RF / Impedance Measurement Basics

Slide #77

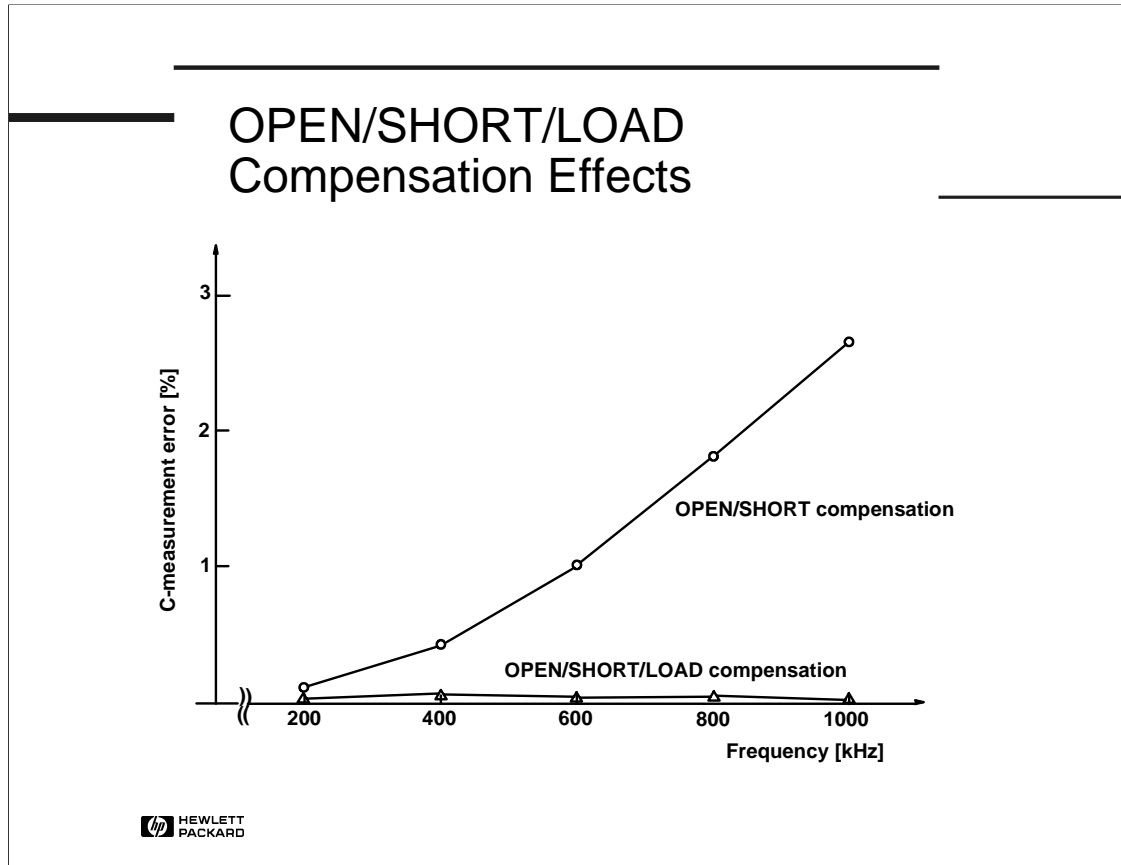

This is an measurement example to show the effects of the OPEN/SHORT/LOAD compensation. In this example, a 100pF capacitor is measured with the HP4285A, extending its test terminals using the HP16048E (4 meter cable) which cannot be corrected with cable correction function. As shown in the plot, the OPEN/SHORT/LOAD compensation can remove the errors which cannot be corrected with the OPEN/SHORT compensation.

(If the test terminals are extended with a long cable at a high frequency, a large phase shift will occur and the measurement circuit can be unbalanced. This problem cannot be solved even with the OPEN/SHORT/LOAD compensation.)

Slide #78

LOAD Device Selection**- Consideration 1 -**

- **When you measure DUTs which have various impedance values,**
 - ➔ **Select a LOAD device whose impedance value is 100Ω ~ 1kΩ.**

- **When you measure a DUT which has only one impedance value,**
 - ➔ **Select a LOAD device whose impedance value is close to that of the DUT to be measured.**

It is important to use a proper LOAD device for accurate measurements.

When measuring the DUT's various impedance values, it is recommended to use a 100 ohm to 1 kohm device as a LOAD, because the LCR Meters/Impedance Analyzers can optimally measure this impedance range with the best accuracy.

When measuring a DUT of one impedance value it is recommended that the LOAD have a impedance value close to that of the DUT.

RF / Impedance Measurement Basics

Slide #79

LOAD Device Selection

- Consideration 2 -

- **Select pure and stable capacitance or resistance loads (low D capacitors - i.e. mica)**
- **LOAD value must be accurately known.**

There is no restriction that an inductor must be used for inductance measurements, or a capacitor must be used for capacitance measurements.

Since the LOAD device must be stable, capacitors or resistors are better suited than inductors. Inductors are more susceptible to environment conditions like humidity and temperature.

When measuring low loss (low D, high Q) DUTs, it is necessary to use a very low loss LOAD. The LOAD's true value must be known accurately.

When measuring the LOAD's true value, it is important to use a test condition with the highest accuracy.

Slide #80

Multi-Path Compensation

- **Scanner Measurement in QA**
 - Port Extension Method
 - Residual Impedance Compensation of Meas Path
- **Handler System in Production**
 - Data Correlation with QA
 - Easy System Integration
 - Contact Check Function for Reliable Testing

RF / Impedance Measurement Basics

Slide #81

Solution for Discrepancy in Measurement Values

MULTI Channel OPEN/SHORT/LOAD Compensation Function

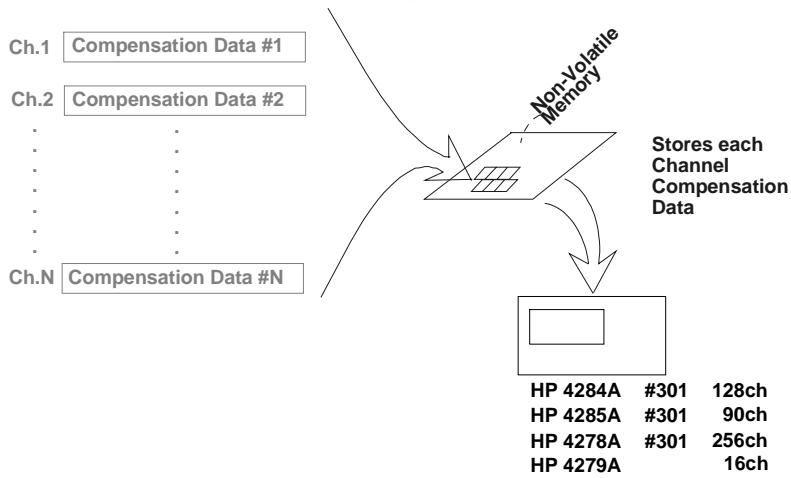

RF / Impedance Measurement Basics

Slide #82

Effectiveness of Load Compensation for Multiple Different Paths

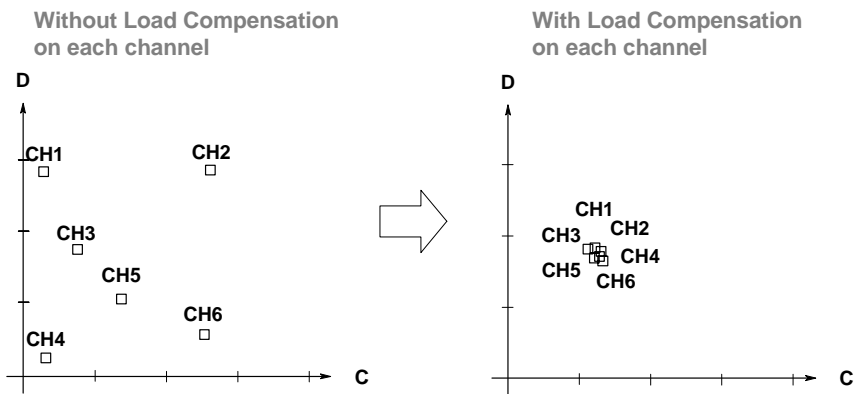

Slide #83

SMD Fixture Requirements

No Metal Parts Near DUT

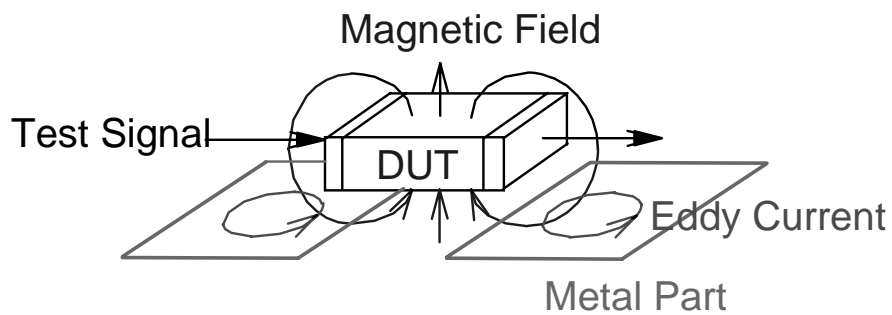

Slide #84

SMD Fixture Requirements

Characteristic Impedance: 50 ohm

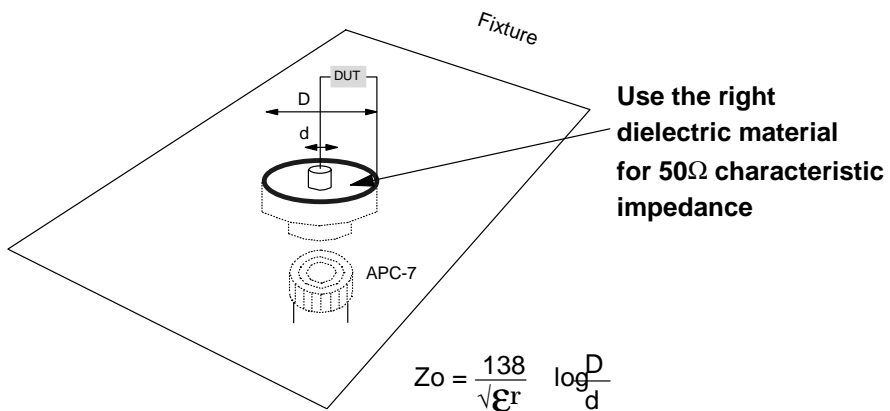

RF / Impedance Measurement Basics

Slide #85

SMD test fixture example HP 16192A

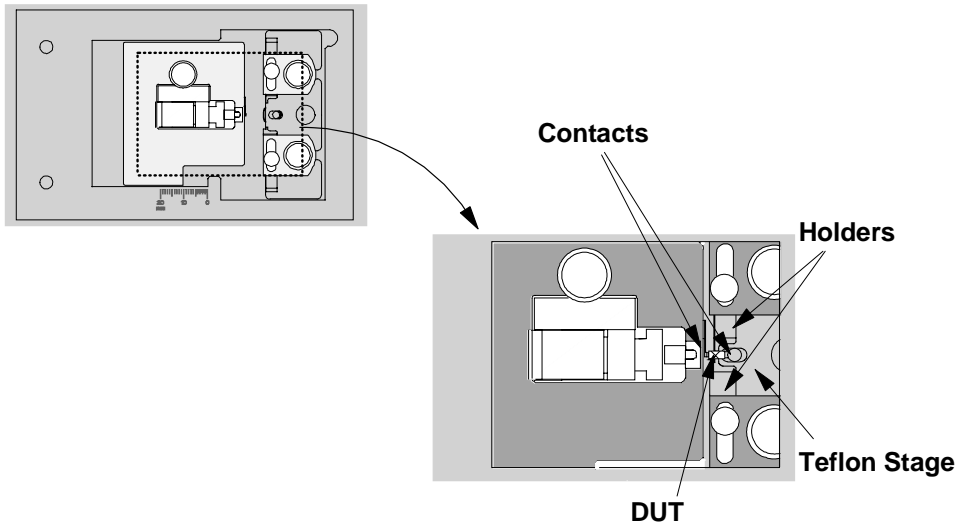

RF / Impedance Measurement Basics

RF Impedance references

<i>HP Lit. Number</i>	<i>Title</i>
◆ 5950-3000	Impedance Measurement Handbook
◆ 5952-1430E	LCR Meter, Impedance Analyzers and Test Fixtures Selection Guide
◆ 5965-1244E	Accessories Selection Guide for Impedance Measurements
◆ 5091-6553E	Effective Impedance Measurement Using OPEN/SHORT/LOAD Correction
◆ 5962-6922E	Evaluating Temperature Characteristics using a Temperature Chamber & the HP 4291A
◆ 5962-6973E	Permittivity Measurements of PC Board and Substrate Materials using the HP 4291A and HP 16453A
◆ 5962-6972E	Permeability Measurements using the HP 4291A and HP 16454A
◆ 5962-9725E	Electronic Characterization of IC Package using the HP 4291A and the Cascade Microtech Prober
◆ 5964-1690E	On-Chip Semiconductor Device Impedance Measurements using the HP 4291A
◆ 5964-6522E	Materials Characterization with a New Dielectric Spectrometer BDS 6000 and the HP 4291A

射频和天线设计培训课程推荐

易迪拓培训(www.edatop.com)由数名来自于研发第一线的资深工程师发起成立,致力并专注于微波、射频、天线设计研发人才的培养;我们于 2006 年整合合并微波 EDA 网(www.mweda.com),现已发展成为国内最大的微波射频和天线设计人才培养基地,成功推出多套微波射频以及天线设计经典培训课程和 ADS、HFSS 等专业软件使用培训课程,广受客户好评;并先后与人民邮电出版社、电子工业出版社合作出版了多本专业图书,帮助数万名工程师提升了专业技术能力。客户遍布中兴通讯、研通高频、埃威航电、国人通信等多家国内知名公司,以及台湾工业技术研究院、永业科技、全一电子等多家台湾地区企业。

易迪拓培训课程列表: <http://www.edatop.com/peixun/rfe/129.html>



射频工程师养成培训课程套装

该套装精选了射频专业基础培训课程、射频仿真设计培训课程和射频电路测量培训课程三个类别共 30 门视频培训课程和 3 本图书教材;旨在引领学员全面学习一个射频工程师需要熟悉、理解和掌握的专业知识和研发设计能力。通过套装的学习,能够让学员完全达到和胜任一个合格的射频工程师的要求...

课程网址: <http://www.edatop.com/peixun/rfe/110.html>

ADS 学习培训课程套装

该套装是迄今国内最全面、最权威的 ADS 培训教程,共包含 10 门 ADS 学习培训课程。课程是由具有多年 ADS 使用经验的微波射频与通信系统设计领域资深专家讲解,并多结合设计实例,由浅入深、详细而又全面地讲解了 ADS 在微波射频电路设计、通信系统设计和电磁仿真设计方面的内容。能让您在最短的时间内学会使用 ADS,迅速提升个人技术能力,把 ADS 真正应用到实际研发工作中去,成为 ADS 设计专家...

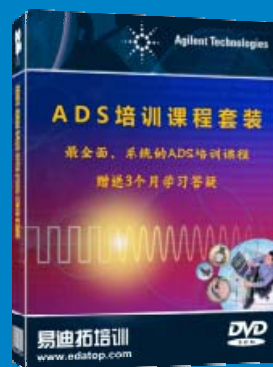

课程网址: <http://www.edatop.com/peixun/ads/13.html>



HFSS 学习培训课程套装

该套课程套装包含了本站全部 HFSS 培训课程,是迄今国内最全面、最专业的 HFSS 培训教程套装,可以帮助您从零开始,全面深入学习 HFSS 的各项功能和在多个方面的工程应用。购买套装,更可超值赠送 3 个月免费学习答疑,随时解答您学习过程中遇到的棘手问题,让您的 HFSS 学习更加轻松顺畅...

课程网址: <http://www.edatop.com/peixun/hfss/11.html>

CST 学习培训课程套装

该培训套装由易迪拓培训联合微波 EDA 网共同推出,是最全面、系统、专业的 CST 微波工作室培训课程套装,所有课程都由经验丰富的专家授课,视频教学,可以帮助您从零开始,全面系统地学习 CST 微波工作的各项功能及其在微波射频、天线设计等领域的设计应用。且购买该套装,还可超值赠送 3 个月免费学习答疑...

课程网址: <http://www.edatop.com/peixun/cst/24.html>



HFSS 天线设计培训课程套装

套装包含 6 门视频课程和 1 本图书,课程从基础讲起,内容由浅入深,理论介绍和实际操作讲解相结合,全面系统的讲解了 HFSS 天线设计的全过程。是国内最全面、最专业的 HFSS 天线设计课程,可以帮助您快速学习掌握如何使用 HFSS 设计天线,让天线设计不再难...

课程网址: <http://www.edatop.com/peixun/hfss/122.html>

13.56MHz NFC/RFID 线圈天线设计培训课程套装

套装包含 4 门视频培训课程,培训将 13.56MHz 线圈天线设计原理和仿真设计实践相结合,全面系统地讲解了 13.56MHz 线圈天线的工作原理、设计方法、设计考量以及使用 HFSS 和 CST 仿真分析线圈天线的具体操作,同时还介绍了 13.56MHz 线圈天线匹配电路的设计和调试。通过该套课程的学习,可以帮助您快速学习掌握 13.56MHz 线圈天线及其匹配电路的原理、设计和调试...

详情浏览: <http://www.edatop.com/peixun/antenna/116.html>



我们的课程优势:

- ※ 成立于 2004 年,10 多年丰富的行业经验,
- ※ 一直致力并专注于微波射频和天线设计工程师的培养,更了解该行业对人才的要求
- ※ 经验丰富的一线资深工程师讲授,结合实际工程案例,直观、实用、易学

联系我们:

- ※ 易迪拓培训官网: <http://www.edatop.com>
- ※ 微波 EDA 网: <http://www.mweda.com>
- ※ 官方淘宝店: <http://shop36920890.taobao.com>